

# **Taxation (Annual Rates for 2021–22, GST, and Remedial Matters) Bill**

---

*Commentary on the Bill*

**Hon David Parker**  
Minister of Revenue

First published in September 2021 by Policy and Regulatory Stewardship, Inland Revenue, PO Box 2198, Wellington 6140.

Taxation (Annual Rates for 2021–22, GST, and Remedial Matters) Bill – commentary on the Bill

ISBN 978-1-98-857328-1 (Online)



© Crown Copyright

This work is licensed under the Creative Commons Attribution 4.0 International Licence. In essence, you are free to copy, distribute and adapt the work, as long as you attribute the work to the Crown and abide by the other licence terms.

The Persistent URL for this document is <https://purl.org/nzir-tp/2021-008>

The document is available at <https://taxpolicy.ird.govt.nz/publications/2021/2021-commentary-argrm-bill>

## CONTENTS

<b>Annual rates for 2021–22</b> .....	<b>7</b>
Annual setting of income tax rates .....	9
<b>GST policy items</b> .....	<b>11</b>
Tax treatment of cryptoassets .....	13
Definition of cryptoasset .....	15
Excluding cryptoassets from GST .....	16
Input credits for capital raising .....	18
Excluding cryptoassets from the financial arrangements rules .....	19
Ability to agree an apportionment method with Inland Revenue.....	21
Disposal of assets with a mix of taxable and non-taxable use .....	22
Domestic transport services supplied as part of the international transport of goods.....	25
<b>Other policy items</b> .....	<b>29</b>
COVID-19 information sharing – removal of time limit .....	31
Offences relating to electronic sales suppression.....	32
Local authority taxation – dividends and deductions .....	36
Fair dividend rate foreign currency hedges .....	42
Use of tax pooling to satisfy a backdated tax liability.....	54
Overseas donee status – section YZ 5 and schedule 32 .....	55
<b>GST remedials</b> .....	<b>59</b>
Modernising information requirements for GST.....	61
Secondhand goods input tax credit – associated persons supplies .....	72
GST input tax recovery for non-resident business .....	74
Exports of goods that are delivered to a recipient’s vessel in New Zealand .....	76
Ground leases paid via a unit title body corporate .....	77
GST B2B compulsory zero-rating of land rules.....	78
GST – deduction notices for members of unincorporated bodies and persons who are no longer registered .....	80
GST groups.....	82
Non-statutory boards .....	86
More flexibility for changing end date for taxable period .....	87
Taxable supplies of goods not yet in physical possession.....	90
Challenge rights – assessing time-barred GST returns.....	91
Remedial amendments to the GST apportionment rules .....	92
Zero-rated supplies of going concerns .....	93
Switching off adjustment provisions after a wash-up is performed .....	94

Repeal redundant provision.....	95
<b>Income tax remedials .....</b>	<b>97</b>
Bright-line test – construction of a main home that takes longer than 12 months .....	99
Bright-line test – no reduction if the main home exclusion does not apply .....	100
Bright-line test – clarifying the application of the 12-month buffer .....	102
Hybrid and branch mismatches – imported mismatch rule .....	104
Early-payment discount rate changes .....	113
Restricted transfer pricing remedials.....	114
Depreciation cost base integrity measure .....	116
Foreign currency loans that finance residential rental property in a foreign jurisdiction.....	117
Fringe benefit tax – unclassified benefits paid by associates .....	118
Election day worker tax code .....	120
Approved issuer levy and security trusts.....	122
Electing into the securitisation regime .....	124
Tax pooling and early-payment discount settings .....	125
Custodial institutions – definition of end investor .....	127
Corporate spin-outs and shareholding continuity.....	128
Share-for-share exchanges and available capital distribution amount .....	130
Debt remission within an economic group.....	134
Employer superannuation contribution tax on contributions for past employees ....	136
Definition of “decommissioning” in the petroleum mining regime.....	137
Ability to refund ancillary taxes .....	139
Amending memorandum accounts when making transfer from previous years .....	140
<b>Other remedials .....</b>	<b>143</b>
Extending use of money interest relief during COVID-19 .....	145
Investment income information – aligning filing and payment date for six-monthly payers of investment income.....	147
Non-active estates return filing .....	148
Repeal of information sharing clauses for the ACC and the Registrar of Companies by an Order In Council.....	149
Commissioner’s remedial powers – disputable decisions .....	150
Challenge notices – whether required after amended assessment issued.....	152
Removing fax as a mode of communication .....	154
R&D Tax Incentive – extension of due dates.....	155
R&D Tax Incentive – tax year cut-off for claiming supporting activities .....	156
R&D Tax Incentive – transitional support payment.....	159
Administrative amendments to the Child Support Act 1991.....	161
Removal of the power to repeal the SFO information sharing clause.....	164
Definitions of “sensitive revenue information” and “revenue information” .....	165
Repeal of transitional co-existence provisions .....	166

Amending and later repealing the definition of “START tax type” .....	167
Preventing circularity of KiwiSaver employer contributions.....	168
ACC and KiwiSaver being made subject to a time bar .....	169
Penalty for failure to keep taxpayer information confidential.....	171
<b>Maintenance items.....</b>	<b>173</b>
Maintenance amendments .....	175



---

## Annual rates for 2021–22

---





## ANNUAL SETTING OF INCOME TAX RATES

---

*(Clause 3)*

### Summary of proposed amendment

The proposed amendment sets the annual income tax rates that would apply for the 2021–22 income tax year. The annual rates that apply to the 2021–22 income tax year include a top personal income tax rate of 39% to annual income exceeding \$180,000.

### Application date

The proposed amendment would apply for the 2021–22 tax year. For most taxpayers, the 2021–22 income tax year commenced on 1 April 2021.

### Key features

The proposed annual income tax rates for the 2021–22 tax year would be set at the rates specified in schedule 1 of the Income Tax Act 2007. The rates include a top personal income tax rate of 39% on annual income that exceeds \$180,000.

The top personal income tax rate of 39% was added by the Taxation (Income Tax Rate and Other Amendments) Act 2020.

### Detailed analysis

Table 1 in part A of schedule 1 of the Income Tax Act 2007 sets out the basic income tax rates that apply to personal income.

**Table 1: Income tax rates**

Row	Taxable income	Tax rate
1	\$0–\$14,000	10.5%
2	\$14,001–\$48,000	17.5%
3	\$48,001–\$70,000	30%
4	\$70,001–\$180,000	33%
5	\$180,001 upwards	39%



---

# GST policy items

---



## TAX TREATMENT OF CRYPTOASSETS

---

### Summary of proposed amendment

The proposed amendments would exclude cryptoassets (also known as cryptocurrencies) from GST and the financial arrangements rules.

### Background

Cryptoassets are digital assets (commonly known as coins or tokens) that use cryptography to secure transactions and verify the transfer of the coins or tokens. Instead of relying on a financial institution to verify transactions, cryptoasset transactions are confirmed by computers operating on the currency's network (distributed ledger technology).

Tax rules in New Zealand and overseas do not contemplate cryptoassets and can be difficult to apply as cryptoassets will often not fit into existing definitions that were designed for other investment products such as currency, shares, debt or equity securities. Because of their innovative nature, they will often also have different features to these other investment products.

### *Cryptoassets and GST*

The current position is that cryptoassets likely fall within the scope of existing GST rules (although this position is unclear). Under current law, the application of GST to cryptoassets would vary depending on the facts, the features of the cryptoasset and the residency of the parties to the transaction. The supply of a cryptoasset could be subject to GST at 15%, an exempt financial service, or a zero-rated supply to a non-resident. The issues that arise when applying GST to cryptoassets can be summarised as follows:

- **Tax settings disincentivising purchasing of cryptoassets by residents:** Applying GST to cryptoassets could result in supplies to non-residents being zero-rated for GST purposes but subject to GST when supplied to residents. This creates a distortion and preference to sell to offshore investors.
- **Double taxation:** This could occur when an asset is purchased with bitcoin and then that bitcoin is converted back into fiat currency.
- **Compliance costs:** If cryptoassets were subject to GST then the GST treatment would vary depending on the classification of the asset (for example, if the cryptoasset was similar to money then it would not be subject to GST, but if it provided access to services then it would). As there are over 10,000 cryptoassets with various functions and constantly changing uses, it would add unnecessary compliance costs to taxpayers if they were required to determine the underlying status of the asset for the purposes of determining whether GST applied.

## *Cryptoassets and the financial arrangements rules*

### **Example 1: Lucy**

Lucy purchases NZ\$11,500 worth of bitcoin from a domestic bitcoin exchange. The exchange is required to remit three twenty-thirds of this (\$1,500) to Inland Revenue as GST on the taxable supply of bitcoin they made in exchange for NZD.

Lucy purchases a car from Smith Motors Ltd using the \$11,500 worth of bitcoin. GST applies on the sale of the car and Smith Motors must return 3/23rds (\$1,500) of the value of the bitcoin to Inland Revenue as GST.

As a result of these two transactions, GST of NZ\$3,000 has been charged in relation to the purchase of a vehicle worth \$10,000. If Lucy had paid for the vehicle with NZD instead of bitcoin, only \$1,500 of GST would have been paid.

From Smith Motors perspective, it receives \$11,500 NZD worth of bitcoin and must return \$1,500 of GST to Inland Revenue for the taxable supply of the car, but it will also need to return another \$1,500 in GST when it converts that bitcoin back to NZD.

The financial arrangements rules are a set of rules that require all returns on “financial arrangements” to be accounted for tax on an accrued basis over the term of the financial arrangement using a spreading method. A “financial arrangement” is broadly defined and includes virtually any arrangement where there is a delay in giving or receiving consideration. A common example of a financial arrangement is a loan. The financial arrangements rules do not apply to “excepted financial arrangements”, which often have their own rules or general rules apply. An example of an excepted financial arrangement are shares.

A person who is subject to the financial arrangements rules must account for all income and expenditure under the rules using an applicable spreading method regardless of whether the financial arrangement is of a revenue or capital nature.

As financial arrangements are broadly defined, this means that some types of cryptoassets are likely to be financial arrangements under the current rules. The application of the financial arrangements rules to cryptoassets could lead to accrual-based taxation on large unrealised gains and losses from cryptoasset values, which can be very volatile. This would require a taxpayer to convert their cryptoassets value into NZD, spread income and expenditure over the time of the arrangement and undertake a base price adjustment on maturity. In addition to these compliance costs, applying the financial arrangements rules to cryptoassets could bias a taxpayer’s investment decision towards cryptoassets not subject to these rules.

## **DEFINITION OF CRYPTOASSET**

---

*(Clauses 5(2), and 127(2))*

### **Summary of proposed amendment**

In order to exclude cryptoassets from GST and the financial arrangements rules, the term “cryptoassets” needs to be defined. The proposed amendment introduces a definition of “cryptoasset” into section 2 of the Goods and Services Tax Act 1985 and YA 1 of the Income Tax Act 2007.

### **Application date**

The proposed amendment would apply from 1 January 2009, the date that the first cryptoasset, bitcoin, was launched.

### **Detailed analysis**

#### ***Meaning of cryptoasset***

The proposed amendment would define cryptoasset widely as a digital representation of value that exists in a distributed ledger (such as a blockchain) and is secured cryptographically to record the ownership and transactions involving cryptoassets. The proposed definition would also future proof it against any technological advancements in the blockchain and cryptography area by including another application of the same technology performing an equivalent function.

To meet the definition of cryptoasset, the asset in question must also be fungible. The fungibility requirement has been included to exclude non-fungible asset classes, such as non-fungible tokens (NFTs). NFTs certify a digital asset to be unique and are not interchangeable. They are generally used to represent items such as photos or videos and can be owned or traded using a blockchain.

## EXCLUDING CRYPTOASSETS FROM GST

---

*(Clauses 5(2) and (3))*

### Summary of proposed amendment

The proposed amendment would exclude cryptoassets from GST by amending the definitions of both “goods” and “services” in section 2(1) of the Goods and Services Tax Act 1985 (GST Act) to expressly exclude cryptoassets. The proposed definition of cryptoassets is explained above – note that this definition excludes non-fungible tokens which will remain subject to GST if supplied by a registered person.

### Application date

The proposed amendment would apply from 1 January 2009, the date that the first cryptoasset, bitcoin, was launched.

### Detailed analysis

Section 8(1) of the GST Act imposes goods and services tax at a rate of 15% on the supply of goods and services in New Zealand by a registered person.

Proposed amendments to the definition of “goods” and “services” in section 2(1) of the GST Act would expressly exclude cryptoassets from these definitions. This means that the supply of cryptoassets would not be subject to GST. However, GST will continue to apply to supplies of goods and services which are bought using cryptoassets (the same as if those goods or services had been purchased using money or swapped for another good or service).

#### **Example 2: Paul**

Paul is a GST registered software developer who develops a new blockchain-based software project and issues a new cryptoasset token to help fund the project. The supply of the cryptoasset token to investors is not a taxable supply for GST as there are no goods or services supplied to the investors in return for their money (or the other cryptocurrency they use to buy the new token).

Six months later the project is successfully launched, and Paul now supplies a blockchain-based software service whereby users of the software can redeem the new cryptoasset token for a monthly subscription to use the software. The supply of the software services is a taxable supply for GST, so Paul must charge 15% GST on the value in New Zealand dollars of sales of the software subscription service to New Zealand customers and zero-rate (charge 0% GST) his sales of software services to non-resident customers. Paul also continues to issue and sell new tokens, but on these are not taxable supplies. Instead, GST applies when the tokens are redeemed for the supply of the software services (similar to a voucher).

#### **Example 3: Bary**

Bary is a GST registered web developer who loves whales. He develops a series of collectible non-fungible tokens using a whale theme. Bary’s tokens become quite popular, and Bary sells them for a total of \$1,150. From a GST perspective, Bary must return \$150 of GST on the sale. This is because non-fungible tokens remain subject to GST.



Because the proposed definition of cryptoassets excludes non-fungible tokens, supplies of non-fungible tokens will remain subject to GST if supplied by a registered person.

## INPUT CREDITS FOR CAPITAL RAISING

---

*(Clause 22)*

### **Summary of proposed amendment**

The proposed amendment would allow GST-registered businesses that raise funds through issuing cryptoassets with features similar to debt or equity securities to claim input tax credits on their capital-raising costs.

### **Application date**

The proposed amendment would apply from 1 April 2017, the date the capital-raising deduction rule took effect.

### **Background**

The GST rules were amended in 2017 to allow GST-registered persons to claim input credits for inputs such as legal or advisory services used to raise capital using equity or debt securities (see section 20H of the Goods and Services Tax Act 1985 (GST Act)).

To ensure businesses that choose to raise capital through issuing cryptoassets are not disadvantaged, the amendment proposes that GST-registered businesses that raise funds through issuing security tokens that have features similar to debt or equity securities (such as a right to a share of the profits of a project) should also be able to claim input credits on their capital-raising costs.

### **Detailed analysis**

Clause 22 would amend section 20H(1)(d) of the GST Act to include cryptoassets with similar features or functions to a debt security, participatory security or equity security (now known collectively as a “funding security”). This treatment would allow businesses that principally make taxable supplies of goods and services to deduct the GST cost of specific costs incurred to raise capital. Examples could include legal fees, exchange listing fees, and costs associated with preparing a product disclosure statement (or whitepaper in the cryptoasset context).

#### **Example 4: Nicole**

Nicole is the founder of a cryptoasset called ‘econo-coin’ which is a revolutionary blockchain based project that aims to create efficiencies in manufacturing production chains through the use of RFID chip technology. These supply chain efficiencies result in saved manufacturing costs for businesses.

Nicole prepares a white paper setting out the purpose of econo-coin and the technology that will be implemented to achieve its goals in order to persuade investors to back the project. Investors who buy an econo-coin are entitled to a share of the profits made by the project, and the econo-coin has similar features or functions to a participatory security.

In issuing the white paper, Nicole spends \$23,000 on legal and consultant fees, including GST of \$3,000. Nicole claims a deduction of \$3,000, the GST component of the costs she incurred to raise capital (with the whitepaper being the promotional tool to achieve this capital raising aim).

## EXCLUDING CRYPTOASSETS FROM THE FINANCIAL ARRANGEMENTS RULES

---

*(Clause 79)*

### Summary of proposed amendment

The proposed amendments would exclude cryptoassets from the financial arrangements rules by amending section EW 5 of the Income Tax Act 2007 (ITA) to include cryptoassets as an excepted financial arrangement.

Officials consider that the issuing of non-fungible tokens are not financial arrangements as they do not meet the definition of a financial arrangement as set out in EW 3 of the ITA.

### Application date

The proposed amendment would apply from 1 January 2009, the date that the first cryptoasset, bitcoin, was launched.

### Detailed analysis

Proposed new section EW 5(3BA) provides that a cryptoasset is an excepted financial arrangement if the cryptoasset does not meet the requirements of subsection (3BAB).

Proposed new section EW 5(3BAB) provides that a cryptoasset is not an excepted financial arrangement if the owner receives amounts that are determined by reference to the purchase price of the cryptoassets and on a basis that is known by the owner in advance. The purpose of this exclusion is to ensure that cryptoassets that are economically equivalent to debt arrangements are still taxed under the financial arrangements rules. This would ensure that cryptoassets receive equivalent treatment to other types of investments.

#### **Example 5: Gordon**

Gordon has 2 bitcoin that he invests via a platform called blockgrowth.co.nz. Blockgrowth is a spread business that makes money by borrowing capital at a certain rate (the interest it pays to users) and lends it at a higher rate. When Gordon invests his bitcoin on the blockgrowth platform, his bitcoin is locked in for a set period and Gordon is paid a guaranteed fixed return in bitcoin for the period that his investment remains locked in to the blockgrowth platform. Gordon invests via blockgrowth for a year and is provided with a 5% return. During this time Gordon is unable to sell, trade, exchange or otherwise make any use of his bitcoin.

After the expiration of the yearly period, Gordon withdraws 2.10 bitcoin from blockgrowth. Although Gordon's underlying investment of 2 bitcoins is not subject to the financial arrangements rules, his additional 5% return, or 0.1 bitcoin is subject to these rules. As Gordon is a cash basis person, this means that Gordon must undertake a base price adjustment on the maturity of this arrangement and pay tax accordingly.

Although in most cases cryptoassets would not be subject to the financial arrangements rules, it is noted that the amounts you get from selling, trading or exchanging cryptoassets can be taxable. You may have to pay tax because you are:

- acquiring cryptoassets for the purposes of disposal (for example to sell or exchange)
- trading in cryptoassets, or
- using cryptoassets for a profit-making scheme.

## **ABILITY TO AGREE AN APPORTIONMENT METHOD WITH INLAND REVENUE**

---

*(Clauses 21(5), and 23(2))*

### **Summary of proposed amendment**

Proposed amendments to sections 20(3EB) and 21(4B) of the Goods and Services Tax Act 1985 would remove the \$24 million turnover threshold for agreeing an apportionment method with the Commissioner. The proposed amendment would allow any registered person to apply to the Commissioner of Inland Revenue to agree to an apportionment method, irrespective of their turnover.

### **Application date**

The proposed amendment would apply from the date of enactment.

### **Detailed analysis**

The apportionment and adjustment rules apply when a GST-registered person uses or intends to use goods and services for both taxable and non-taxable purposes.

Following the acquisition of an asset, the apportionment rules require the GST-registered person to annually compare the intended taxable use of an asset with the actual taxable use of an asset. If there is a difference the person must make an adjustment to either claim extra input tax credits or pay output tax to reflect the actual taxable use of the asset.

Under current law, only registered persons that expect to make supplies of goods and services with a value of more than \$24 million in a 12-month period can agree to an apportionment method with the Commissioner. GST registered persons below this threshold are currently unable to negotiate a specific apportionment method with the Commissioner, and must apply rules that can be seen as complex.

Removing the threshold would reduce compliance costs by allowing all registered persons to apply to the Commissioner to agree to an apportionment method.

## **DISPOSAL OF ASSETS WITH A MIX OF TAXABLE AND NON-TAXABLE USE**

---

*(Clause 25)*

### **Summary of proposed amendment**

Section 21F of the Goods and Services Tax Act 1985 (GST Act) applies when a GST registered person disposes of an asset which they have partly used to make taxable supplies and also partly used for a non-taxable use (such as a private or exempt use). It allows them to claim an additional input tax deduction in respect of their non-taxable use of an asset. However, this deduction is currently capped at the GST fraction of the purchase price paid by the registered person when they acquired the asset.

The proposed amendment to section 21F would remove this cap on deductions to ensure that disposals of appreciating assets, such as land, are not overtaxed.

It is proposed that the cap would remain in place for land disposed of by property developers as an increase in the value of the land in these cases is directly connected to their taxable activity of property development.

### **Application date**

The proposed amendments would apply from 24 February 2020.

### **Detailed analysis**

Section 21F applies when a registered person disposes of an asset which during their period of ownership they have partly used to make taxable supplies and also partly used for a non-taxable use (such as to make exempt supplies, private use or using the asset before registering for GST).

It allows the person to claim an additional input tax deduction to reflect the non-taxable use of the asset. This input tax deduction is in addition to any input tax deduction already claimed in respect of the percentage use of the asset to make taxable supplies. The additional deduction offsets the output tax which the registered person is required to return on the disposal of any goods or services used in the course or furtherance of their taxable activity.

The current section 21F of the GST Act caps the input tax deduction to the tax fraction (3/23rds) of the consideration paid when the asset was acquired (or 15% of the consideration in cases where the land was acquired as a zero-rated supply). This cap on deductions can lead to appreciating assets such as land being overtaxed on disposal, as it means that while any increase in the value of the asset is subject to output tax, there is no corresponding input tax deduction to reflect any non-taxable use of the asset.

There are currently two separate formulae in sections 21F(2) and (4) that, while expressed differently, actually calculate exactly the same amounts. Currently, application of the formula in section 21F(4) is limited to land that was a zero-rated supply under 11(1)(mb) at the time it was acquired by the registered person who is now disposing of the land.

Because the formula in section 21F(4) is simpler and easier to understand than the formula in section 21F(2) of the GST Act, the proposed amendment would repeal section 21F(2) and expand the application of section 21F(4) so the simpler formula in section 21F(4) would apply to all assets.

### ***A cap on input tax deductions is retained for property developers***

The policy intention is that the existing cap on input tax deductions under section 21F should remain in place for land disposed of by a property developer. This is because their taxable activity is about improving the value of land so any appreciation in value of the land is directly connected to their taxable activity.

To retain a cap on property developers, the proposed amendment would replace the current section 21F(6) with a new proposed section 21F(6) that would apply to GST-registered property developers whose taxable activity is supplying land (as a good). More specifically, the proposed section 21F(6) would apply to a disposal of land, which would be a taxable supply in the course or furtherance of a taxable activity of supplying land even in the absence of any other use of the land by the person in a taxable activity.

If, instead, the registered person uses the land to conduct another type of taxable activity, such as short-term commercial accommodation or a home-based business, and the land would not have been a taxable supply in the absence of that other type of taxable activity, new section 21F(6) would not apply and the formula in section 21F(4) would allow an uncapped input tax deduction that reflects the percentage of non-taxable use of the land. This is illustrated in example 6.

#### **Example 6: Short-term commercial accommodation**

Sally purchases a home in Whangamatā for \$690,000. The holiday home is used to supply short-term commercial accommodation and because the expected revenues from this activity will exceed \$60,000 per annum, Sally registers for, and charges GST on the short-term accommodation.

As Sally has also stayed in the holiday home for long periods over the winter months, her private (non-taxable) use of the house has been 20%. Because the taxable use of the holiday home is 80%, Sally has already claimed an input tax deduction of \$72,000 during her period of ownership (\$72,000 is 80% of the tax fraction (3/23rds) of the \$690,000 purchase price of the house).

After many years she sells the holiday home for \$1,150,000 (including GST). As Sally is GST registered and disposing of an asset which was used in the course and furtherance of her taxable activity of supplying short-term commercial accommodation, she is required to return \$150,000 of GST output tax.

Sally does not have a taxable activity of selling land. This means that in the absence of the supplies of short-term commercial accommodation Sally made from the holiday home, the sale of the holiday home would not be considered as being made in the course or furtherance of a taxable activity. Under the proposed change in the Bill the cap on adjustments in section 21F would therefore not apply to the disposal of the holiday home so Sally can claim an input tax deduction of \$30,000.

Applying the formula in proposed section 21F(4) to Sally's holiday home:

$$\begin{aligned} & \text{Tax fraction} \times \text{consideration} \times (1 - \text{previous use}) \\ = & \quad \frac{3}{23} \quad \times \$1,150,000 \quad \times (1 - 0.8) \\ = & \$30,000 \end{aligned}$$

Sally returns \$150,000 of GST output tax and claims an input tax deduction of \$30,000 in her next GST return. The \$120,000 of net GST she returns reflects 80% of the output tax charged on the sale of the holiday home which is consistent with the fact that 80% of the holiday home was used to make taxable supplies.

If the person who is disposing of the land is a property developer, so that the cap in proposed section 21F(6) applies to them, then how the cap is calculated depends on whether the land was acquired as a zero-rated supply of land.

If the property developer acquired the land as a zero-rated supply, paragraph (a) would apply to limit the maximum input tax deduction under section 21F to 15% of the consideration paid on purchase (the amount calculated under 20(3J)(a)(iii) with a 15% GST rate).

For other types of land, including land acquired as a secondhand good, paragraph (b) would apply to limit the maximum input tax deduction for a property developer under section 21F to the full input tax deduction (3/23rds) of the consideration the developer paid when they acquired the land. The limit on input tax deductions for property developers is illustrated in example 7.

**Example 7: Property developer**

House Co is a GST registered property developer that purchases a house on a large section of land for \$2.3 million from an unregistered person that is currently rented out as residential accommodation. Six months later the residential tenancy ends and they begin renting out the house as short-term commercial accommodation while developing plans and obtaining consent for development work.

After six months of using the home for providing short-term commercial accommodation House Co begins the process of demolishing the house, subdividing the land and constructing five new houses on the land.

Two years after acquiring the land House Co sells the five new houses for a total price of \$5.75 million (including GST) and returns output tax of \$750,000.

House Co has a taxable activity of property development and therefore, even in the absence of the supplies of short-term commercial accommodation they made with the land, the supply of the land would still be made in the course or furtherance of a taxable activity. As such, the cap on adjustments in the current section 21F and the proposed new section 21F(6) would apply to the disposal of the land.

Proposed section 21F(6)(b) caps the maximum input tax deduction to the tax fraction of the purchase price that House Co paid when they acquired the land which is \$300,000 ( $3/23 \times \$2.3 \text{ million} = \$300,000$ ).

Over the period House Co owned the land their taxable use was 75% so they had claimed an input tax deduction of \$225,000. House Co's additional input tax deduction under section 21F would therefore be capped at \$750,000 as this is the remainder of the \$300,000 tax fraction on the \$2.3 million purchase price.



## **DOMESTIC TRANSPORT SERVICES SUPPLIED AS PART OF THE INTERNATIONAL TRANSPORT OF GOODS**

---

### *(Clause 11)*

#### **Summary of proposed amendment**

The Goods and Services Act 1985 (GST Act) zero-rates services provided to transport goods to and from New Zealand. This is because exported goods are zero-rated, and the value of transport services for imported goods are already included in the cost of imported goods, which are subject to 15% GST.

Under the current law, the transport of goods within New Zealand – where the service forms part of the international transport of goods – may also be zero-rated, but only when these services are supplied by the same supplier as the international transport (that is, they are not subcontracted to another supplier).

The proposed amendment would expand zero-rating to accommodate sub-contracting arrangements. This would mean that domestic transport services supplied to a primary transport supplier (often a non-resident/international transporter) to transport goods to or from New Zealand would be zero-rated.

#### **Application date**

The proposed amendment would apply from the date of enactment.

#### **Key features**

The proposed amendment to section 11A(1)(c) of the GST Act would remove the words “to the extent that the services are supplied by the same supplier”, which would enable domestic transport suppliers to subject their domestic transport services (where they relate to the international transport of goods) to 0% GST.

#### **Background**

The current rules for when domestic transport services that form part of the international transport of goods must be zero-rated do not align with current commercial practices. It is a common commercial practice for an international transport supplier, contracted to supply the international transport of goods to or from New Zealand, to subcontract the domestic transport component to a New Zealand-based transport supplier (for example, a courier company) – instead of the international transport supplier establishing themselves in New Zealand in order to complete the domestic component of the transport service themselves.

However, currently the rules require the primary transport supplier to also be the same supplier of the domestic transport component (essentially the primary transport supplier provides the full transport service). The issue is the requirement of “same supplier” has been interpreted strictly – meaning subcontract and other common commercial arrangements, even where the domestic transport supplier is a wholly owned subsidiary of the international transport supplier, have been outside the scope of the zero-rating rule. This has meant that

domestic transport suppliers have been required to impose 15% on the domestic transport service. There are circumstances where 15% GST has been charged and the international transporter is unable to claim back the GST charged to them.

The current rules have also led to non-compliance within the goods transportation industry. Officials understand that many goods transporters are incorrectly zero-rating their domestic transport services – either due to a lack of understanding of the requirements or intentionally due to significant commercial pressure in order to remain competitive in the marketplace.

### ***Voluntary compliance can result in tax cascades***

Where a domestic transporter has chosen to adhere to the current rules, it is possible that the primary transporter is not registered for GST in New Zealand, resulting in the undesirable outcome of tax cascades – where the GST is absorbed by the business as a cost and consequently becomes embedded in the price charged for the international transport of goods (instead of being separated out on the invoice and claimable), and ultimately embedded in the price of the goods being transported.

While the effect of tax cascades could be avoided if the non-resident chose to register for GST in New Zealand, many chose not to do so, due to compliance costs and other commercial reasons. Consequently, the unregistered transporters are unable to claim a refund on the GST incurred.

In many situations, the GST is either an unrecoverable GST cost for the unregistered transport business, or the domestic transporter erroneously does not charge GST for their service.

### **Detailed analysis**

#### ***Removal of “to the extent that the services are supplied by the same supplier”***

The proposed amendment to section 11A(1)(c) would result in subcontracting arrangements and other common commercial arrangements being in-scope of the zero-rating rule. This means all domestic transport services supplied to a primary transport supplier contracted to transport goods to or from New Zealand would be zero-rated, regardless of whether the transporter is one and the same and regardless of the residency of the primary transport supplier.

The proposed zero-rating rule applies regardless of the residency of the primary transport supplier.

#### ***Goods transported into New Zealand***

Consistent with the existing policy intent of section 11A(1)(a), it is proposed that if the international transport supplier is contracted to deliver goods from point A outside New Zealand to point B in New Zealand, then the transporter can zero-rate the entire supply.

Any domestic transport services contractually supplied to the international primary transport supplier to move goods within New Zealand, in order to fulfil the whole transport service to the customer, would also be zero-rated.

**Example 8: Goods being transported from a place in New Zealand to a place outside New Zealand**

Scotty's Shipping is contracted by a customer to transport goods from Thorndon, Wellington to New York City. Scotty's Shipping subcontracts Lucy's e-Lorries, a domestic all-electric trucking company based in Wellington, to transport the goods from Thorndon to Auckland. From Auckland, Scotty's Shipping then transports the goods to New York City.

Under the proposed rules, Lucy's e-Lorries would zero-rate (charge 0% GST) on the supply to Scotty's Shipping.

While the supply of the domestic transport services by Lucy's e-Lorries is between one point in New Zealand to another point in New Zealand, the service is actually being supplied to Scotty's Shipping as part of the supply of transport services whose end destination is outside New Zealand.

***Goods transported out of New Zealand***

Likewise, if the international primary transport supplier is contracted to transport goods from point A in New Zealand to point B outside New Zealand, then they can zero-rate this entire supply. Any domestic transport services contractually supplied to the international transport supplier between point A and point B would also be zero-rated.

**Example 9: Goods being transported from a place outside New Zealand to a place in New Zealand**

WILL-Transport, an international transport supplier of luxury vehicles, is contracted by a customer to transport their German-made vehicle from Huddersfield England, to Oamaru New Zealand. WILL-Transport transports the vehicle from England to Auckland and subcontracts Auto Bens Couriers (ABC) to provide the domestic transport service between Auckland and Wellington.

Under the current rules, ABC must charge 15% GST on its supply to WILL-Transport. This is because WILL-Transport and ABC are different entities.

Under the proposed rules ABC would zero-rate (charge 0% GST) its supply of domestic transport services as the supply is part of the supply of transporting goods outside New Zealand and the supply is being provided to the primary transport supplier.

***Evidence to determine the origin or destination of the goods***

To support the GST treatment of a particular supply of transport services and whether a particular good is being exported/imported as part of an international transport service, taxpayers and transporters should rely on existing documentation that usually accompanies a particular shipment. This includes intermodal freight transport, such as Bill of lading (shipping lines) or Airway Bills (airlines), or other relevant transport documents including "track and trace" and other digital-based shipping documentation tools. Many of these documents are required for Customs purposes.

Given the widespread use of "track and trace" and other digital-based shipping documentation tools, it should make it relatively straightforward to identify shipments that are intended for international transportation.



---

## Other policy items

---



## **COVID-19 INFORMATION SHARING – REMOVAL OF TIME LIMIT**

---

*(Clause 173(1))*

### **Summary of proposed amendment**

The proposed change would remove the current time limit on schedule 7, clause 23B of the Tax Administration Act 1994, which enables information sharing between government agencies for COVID-19 related initiatives.

### **Application date**

The proposed amendment would apply from the date of enactment.

### **Background**

Schedule 7, clause 23B enables information sharing between government agencies for COVID-19 purposes and includes a sunset clause, meaning it ceases to be in effect once 24 months have passed from the date of the clause commencing. This time limit can be extended by an Order in Council, which must be made before the expiry of the 24-month period.

The proposed change would remove the time limit from schedule 7, clause 23B, meaning it would remain in effect without the need for repeat extension using an Order in Council. This would future proof these powers, ensuring agencies can share needed information throughout the entire life cycle of the pandemic and the initiatives that support New Zealand's recovery.

Having an open-ended time limit on these provisions would not remove current limitations on information sharing. They would continue to be tied specifically to the delivery and administration of relevant COVID-19 related initiatives. The provision would therefore inherently self-limiting in the powers it provides.

## OFFENCES RELATING TO ELECTRONIC SALES SUPPRESSION

---

*(Clauses 160–162, and 165)*

### **Summary of proposed amendment**

The proposed amendments would introduce a penalty regime intended to prevent the spread of electronic sales suppression tools within the New Zealand tax base. They would establish a criminal penalty for the manufacture or distribution of suppression tools and criminal and civil penalties for the acquisition or possession of suppression tools.

All section references in this section are to the Tax Administration Act 1994 (TAA).

### **Application date**

The proposed amendments would apply from the date of enactment.

### **Key features**

The features of the proposed amendments are:

- Proposed section 143BB would establish a criminal penalty for the manufacture or supply of a suppression tool. A person convicted of an offence under the proposed penalty would be liable to a fine of up to \$250,000.
- Proposed section 143BC would establish a criminal penalty for the acquisition or possession of a suppression tool. A person convicted of an offence under the proposed penalty would be liable to a fine of up to \$50,000.
- Proposed section 141EE would establish a civil penalty of \$5,000 for the acquisition or possession of a suppression tool.
- Proposed section 141FB(6) would remove the fifty percent prior behaviour reduction of shortfall penalties for evasion where the use of a suppression tool contributed to that evasion.
- Proposed section 141GB would provide a voluntary disclosure reduction in the civil penalty similar to that which already exists for shortfall penalties under section 141G.

### **Background**

Electronic sales suppression tools are software programs, devices, or other tools that systematically alter point-of-sale data collected by a business to understate or completely conceal revenues, which facilitates tax evasion. These tools can work in a variety of ways, targeting the integrity of transactions, software, internal memory, external filing, or reporting to delete, change, or simply not record select sales data and transactions.

Unlike a number of other jurisdictions including Australia, the United Kingdom and Canada, electronic sales suppression is not currently specifically considered in New Zealand law. While using a suppression tool constitutes tax evasion and can be penalised under existing anti-evasion provisions, it is not currently illegal to manufacture, sell, buy, or possess such tools. The spread of electronic sales suppression poses risks to the integrity of the tax system,



as suppressing sales data allows businesses to more easily evade their income tax and GST obligations.

Preventing the spread of suppression tools is therefore vital to maintaining the integrity of the tax base. The proposed new penalties would allow Inland Revenue to specifically target suppliers and taxpayers possessing suppression tools, which is likely to be a more efficient means of preventing the spread of the tools than solely prosecuting end-users under existing evasion penalties. The desired outcome is that taxpayers are deterred from adopting the tools, which helps maintain the integrity of the tax base.

## **Detailed analysis**

### ***Definitions***

Two amendments are proposed to section 3, which defines terms used elsewhere in the TAA.

The first proposed amendment would introduce a definition of an electronic sales suppression tool. Electronic sales suppression tools would include a software program, device, or other thing, part of a thing, or combination of things or parts. The proposed definition is written broadly and intended to encompass both physical and digital tools.

To be an electronic sales suppression tool, a tool would need to meet two criteria:

- it must be able to modify, falsify, destroy, or prevent the creation of a record created by an electronic point of sale system that a person is required to keep under a tax law, and
- the use of the tool would lead to a reasonable conclusion that one of its principal functions is to facilitate the modification, falsification, destruction, or prevention of such a record.

The proposed criteria are intended to avoid the issues inherent to using a highly specific definition of a suppression tool (for example, accidentally capturing software that modifies sales data for legitimate reasons, such as correcting input errors or training staff). This would allow for the targeting of tools intended for the purposes of sales suppression while avoiding similar tools that are not used for malicious purposes. The proposed definition is closely modelled on a similar definition used in Australia.<sup>1</sup>

The second proposed amendment would add the sales suppression penalty to the definition of a civil penalty.

### ***New penalties relating to suppression tools (proposed sections 143BB, 143BC, 141EE)***

The proposed amendments would add three new sections to the TAA, to provide penalties targeting the manufacture, provision, acquisition, or possession of suppression tools. Proposed new section 143BB provides for a criminal penalty targeting the manufacture or provision of suppression tools, while proposed new section 143BC provides for a criminal penalty targeting the acquisition or possession of such tools. Proposed new section 141EE also provides a civil penalty for acquisition or possession.

---

<sup>1</sup> Refer to the definition of an electronic sales suppression tool in section 8WAB of the Taxation Administration Act 1953.

### *Criminal penalty for manufacture or provision of suppression tools (section 143BB)*

Proposed new section 143BB would establish a criminal penalty for either of these two acts:

- Manufacturing, developing, or publishing a suppression tool. The penalty would apply where the tool is provided to a New Zealand resident who is liable for a sales suppression penalty or an intermediary who ultimately provides it to a New Zealand resident (subsection (1)).
- Knowingly supplying, making available for use, or otherwise providing a suppression tool to a person resident in New Zealand, including a right to use a tool or a service including the use of a tool (subsection (2)).

The proposed penalty for committing these offences would be a fine up to a maximum of \$250,000 (subsection (3)). As this is a criminal penalty, the size of an individual fine would be determined by a court allowing for variation based on a taxpayer's circumstances.

### *Criminal penalty for acquisition or possession of suppression tools (section 143BC)*

Proposed new section 143BC would establish a criminal penalty for taxpayers required to keep records under a tax law who knowingly acquire or possess a suppression tool with the purpose of using it to evade the assessment or payment of tax (subsection (1)).

The proposed penalty for committing this offence would be a fine of up to a maximum of \$50,000 (subsection (3)). As with the proposed penalty for manufacture or provision in new section 143BB, and for similar reasons, the size of an individual fine would be determined by a court.

Proposed subsection (4) provides that a taxpayer who possesses the tool for multiple periods commits a single offence and therefore would only be liable for a single penalty, for all tax types and periods, from when the tool was acquired until the penalty is imposed. This subsection would also allow for the proposed penalty to be imposed again if the taxpayer continues to possess the tool after the first penalty was applied.

Proposed subsection (2) provides that the penalty would not apply to taxpayers who acquire a business whose operations include the use of a suppression tool, where the taxpayer could not reasonably have known of the tool's existence and has not used the tool. This is intended to ensure, for the avoidance of doubt, that taxpayers who accidentally acquire a tool in this way are not penalised for this unintentional acquisition.

As subsection (1) states an offence is only committed when the person has a purpose of evading the assessment or payment of tax, subsection (5) would strengthen this provision by treating the person as meeting the purpose test in subsection (1)(c) if they have used the tool to evade the assessment or payment of tax. A person who has acquired or possesses the tool but has not used it to evade the assessment or payment of tax could still have committed an offence if they had a purpose of doing so.

### *Civil penalty for acquisition or possession of suppression tools (section 141EE)*

Proposed new section 141EE would establish a civil penalty for taxpayers who acquire or possess a suppression tool with the purpose of using it to evade the assessment or payment of tax (defined in subsection (1)), and includes an exception for taxpayers who acquire a tool unwittingly through acquiring a business that includes a tool (subsection (2)). The proposed

subsections are intended to operate identically to the corresponding parts of proposed section 143BC.

Proposed subsection (3) would set the penalty amount at \$5,000. This smaller civil penalty would allow Inland Revenue discretion to prosecute major offenders using criminal penalties, while applying the civil penalty against smaller offenders (potentially in addition to existing civil evasion shortfall penalties). The proposed approach is based on the operational experience of the Australian Taxation Office, which has noted that users of suppression tools can be very high in number and the cost-effective approach to these users is to levy civil penalties against them, rather than having to take them individually through the courts, to impose criminal penalties.

Consistent with proposed section 143BB(4), proposed section 141EE(4) would also prescribe that the penalty can only be imposed once for all tax types and periods, after which a further penalty may be imposed for continued possession of the tool.

#### ***Previous behaviour penalty reduction amendment (section 141FB)***

Section 141FB of the TAA provides for a fifty percent reduction for tax shortfall penalties imposed under various other sections of the TAA where the taxpayer has no prior history of incurring relevant shortfall penalties. This is intended to provide leniency in situations where a taxpayer has no prior history of non-compliance. However, evasion involving a suppression tool requires the taxpayer to acquire the tool (itself a premeditated act of non-compliance) and therefore establishes a history of intended non-compliance.

An amendment is proposed to section 141FB, adding new subsection (6). This proposed subsection would disable the fifty percent shortfall penalty reduction when a taxpayer is liable for a shortfall penalty for evasion or a similar act where an electronic sales suppression penalty has been imposed on the taxpayer under section 141EE and the use of the suppression tool contributed to the evasion or similar act.

#### ***Voluntary disclosures (proposed section 141GB)***

Section 141G of the TAA allows for reductions in the amount of certain shortfall penalties for which a taxpayer is liable if the Commissioner deems that the taxpayer has made a full voluntary disclosure of the shortfall. However, section 141G cannot easily be applied to a penalty under section 141EE, as a voluntary disclosure must include full details of the tax shortfall and an electronic sales suppression penalty does not, in itself, arise from a tax shortfall. Instead, the proposed amendment mirrors many of the concepts from existing section 141G in proposed new section 141GB. This section refers to “disclosures” rather than “voluntary disclosures” to provide separation from the use of that term in section 141G and confirm that it is not necessary to provide details of a tax shortfall to satisfy proposed section 141GB; although any tax shortfall would still be required to be disclosed if the disclosure is to satisfy section 141G.

As with section 141G, a disclosure of possession of an electronic sales suppression tool can be either pre-notification (where the disclosure was made before the taxpayer was notified of a pending audit or investigation) or post-notification (where it was made after the taxpayer was notified of the audit or investigation). The level of reduction for a pre-notification disclosure is one hundred percent compared to forty percent for a post-notification disclosure.

## LOCAL AUTHORITY TAXATION – DIVIDENDS AND DEDUCTIONS

---

*(Clauses 54, 55, 58–60, 62, 63, 83, 91, 108, 109, and 116)*

### Summary of proposed amendments

These proposed amendments would improve the integrity of local government taxation:

- Treat dividends derived by a local authority from a wholly-owned council-controlled organisation (CCO), port company and energy company as exempt income.
- Local authorities would no longer be allowed a deduction for charitable or other public benefit gifts made to donee organisations.
- Ensure that a local authority's deductions for finance costs (including finance costs relating to financial derivatives such as interest rate hedges) would be limited to finance costs incurred:
  - on loans made to a council-controlled trading organisation<sup>2</sup> (CCTO)
  - on borrowings to acquire shares in a group company that is a CCTO, and
  - on base price adjustments for financial arrangements involving CCTOs.
- Local authorities would no longer be permitted to convert unused imputation credits to a tax loss.
- Ensure that a credit would not arise to a consolidated group's imputation credit account (ICA) for imputation credits attached to a dividend derived by a local authority.

### Application date

The proposed amendments would apply for the 2022–23 and later income years, except for one maintenance change (clause 62) which would apply from the date of enactment.

### Key features

#### *Dividends*

Inter-corporate dividends paid between New Zealand resident companies are tax exempt where there is 100% common ownership. Dividends paid to the Crown from State enterprises, and to charities from their wholly-owned companies, are similarly tax-exempt.

The proposed amendment would provide consistency with these exemptions by treating dividends derived by a local authority from a wholly-owned CCO as exempt income.

#### *Deductions*

Current law allows local authorities tax deductions for some expenditure not incurred in deriving assessable income (such as corporate gift deductions and certain finance costs).

---

<sup>2</sup> A council-controlled trading organisation (CCTO) is a CCO that operates a trading undertaking for the purpose of making a profit.

These deductions result in local authorities having tax losses despite being largely exempt from tax. These losses can be used under the loss grouping rules to reduce the taxable income of group companies (companies in which a local authority has at least 66% ownership).

#### *Corporate deductions for a charitable or other public benefit gift*

The proposed amendment would prevent a local authority accessing the corporate deduction for a charitable or other public benefit gift. Data shows that local authorities have been consistently the largest group of companies that have used this deduction, despite their substantively tax-exempt status.

#### *Finance costs*

The proposed amendments would limit deductions for finance costs. Finance costs include interest expenses and deductions for financial arrangements that are not interest expenses. The proposed amendments would limit deductions of a local authority for finance costs to the following situations:

- interest incurred on money borrowed that is on-lent to a CCTO
- interest incurred on money borrowed to capitalise a group company that is a CCTO, and
- a negative base price adjustment for financial arrangements involving CCTOs.

#### *Imputation credits attached to dividends received*

A person is entitled to an imputation credit only if the credit is included in their assessable income. A consequence of the proposed amendment to exempt dividends derived by a local authority from wholly-owned CCOs is that the local authority would no longer receive a tax credit for imputation credits attached to dividends from a wholly-owned CCO.

The proposed amendments mean that a local authority would not be permitted to convert any unused imputation credits to a tax loss.

#### *Imputation credit accounts*

The proposed amendment means that a local authority that is a member of a consolidated group would not be able to make a credit entry to the group's imputation credit account (ICA) for dividends received from a group member. This proposed change is consistent with the legislative settings for a local authority not being allowed to maintain an ICA on its own account.

### **Background**

The current tax policy settings for local authorities stem from local government reforms of the late 1980s. Broadly speaking, since these reforms the tax settings for local authorities have been as follows:

- A local authority is generally tax-exempt on its income (primarily rates) derived from its core services (for example, parking fees).
- However, a local authority is taxable on all income (for example, rent, management fees and dividends) derived from a CCO, an energy company or a port company (trading subsidiaries of a local authority). A CCO itself is taxable.

The proposal to treat dividends derived by a local authority from a CCO as exempt income was supported by the local government sector in discussions with Inland Revenue officials in 2019.

Officials also consulted with the local government sector in the first half of 2021 on the application of the loss grouping rules to local authorities. This consultation focused on improving the integrity of the tax system given the substantive exemption from income tax for income earned by local authorities.

In this later consultation, feedback was sought on a broader proposal to deny loss grouping between a local authority and its CCOs. Submissions on this proposal considered that a local authority with tax losses should be entitled to offset any losses against the income of other taxable entities within their group. Some submissions indicated support for limiting deductions that gave rise to integrity concerns.

## **Detailed analysis**

### ***Dividends***

Under current law, the income of a local authority is exempt from income tax except for income earned from a CCO, a port company or an energy company.

The purpose of taxing income derived by a local authority from these types of entities is to prevent profit shifting from these taxable entities to exempt local authorities. Without this provision, income from a CCO could be extracted tax-free by the local authority charging the CCO above-market rental or management fees, which would be deductible to the CCO but not taxable to the local authority due to its tax-exempt status.

Taxing local authorities on dividends derived from their CCOs is inconsistent with similar entities, such as the Crown and State enterprises, or charities. Inter-corporate dividends paid between New Zealand resident companies are exempt where there is 100% common ownership. This exemption currently does not apply to dividends derived by local authorities from their CCOs.

As a dividend is not a deductible expense of a CCO, there are no profit shifting concerns with treating the dividend as exempt income of the local authority. Under the proposed amendments, dividends paid by a wholly-owned subsidiary of a local authority that is a CCO, energy company, or a port company would be exempt income of the local authority.

The proposed amendments would improve the coherence of the tax system by providing consistency with the rules exempting dividends paid within wholly owned groups, as a number of CCOs are wholly owned by one local authority.

### ***Deductions***

Broadly, under current law, a local authority is allowed deductions for any costs incurred to the extent they are incurred in deriving assessable income of the local authority (for example, management fees paid by CCOs to councils). This statutory test is often referred to as the nexus test.

However, no deduction is allowed for costs incurred in providing core services, as these services are generally primarily funded from rates income and other exempt income streams.

However, current law allows local authorities certain deductions for expenditure without being required to meet the nexus test. Examples of deductions that are not required to meet the nexus test include the corporate gift deduction and certain deductions for finance costs.

It has been identified that access to these deductions has allowed local authorities to have tax losses, despite being largely exempt from tax. These tax losses can be used under the grouping rules to reduce the taxable income of CCOs.

### *Corporate gift deductions*

Changes to the application of the corporate gift deduction provision from the 2008–09 income year allowed companies a deduction for charitable donations to donee organisations, subject to the deduction not exceeding the company’s net income. It was not clear that specific consideration was given at the time to whether local authorities should have access to this provision. As current law treats a local authority as a company, the corporate gift deduction is available to a local authority.

The corporate gift deduction is intended to encourage companies to redirect part of their otherwise taxable income to charitable, benevolent, philanthropic or cultural purposes. The corporate gift deduction is not intended to be available for primarily exempt entities like local authorities. In particular, it is not intended to provide a tax subsidy for donations made by local authorities whose legislated purpose is to promote the social, economic, environmental, and cultural well-being of communities.

Currently, local authorities can offset corporate gift deductions against dividend income from their CCOs. This results in imputation credits attached to those dividends being unused, which are then converted to a tax loss and used to reduce the taxable income of the local authority’s CCOs under the loss grouping rules. This arrangement can result in local authorities transferring the benefit of their exempt status to their taxable CCOs, contrary to the policy intent.

The proposed amendments would also change the crossheading above section DB 41 from “Marketing” to “Corporate gifting” to represent the purpose of this section more accurately.

### *Finance costs*

Under current settings, a local authority is allowed a deduction:

- for interest expenses incurred on money that has been borrowed to derive assessable income
- for interest expenses incurred on money borrowed to capitalise a subsidiary company
- for finance costs relating to annual valuation movements on financial arrangements (for example, interest rate hedges). These finance costs are treated as an interest expense for income tax purposes, and
- for finance costs arising under a wash-up calculation when a financial arrangement ends. This wash-up calculation is known as the base price adjustment (BPA). A statutory deduction arises if the BPA results in a negative amount. This statutory deduction is not required to meet the nexus test.

Given the mainly exempt status of a local authority, the proposed amendments would clarify:

- the extent to which a deduction for interest expenses would be allowed for a local authority, and
- the extent to which the statutory deduction for the BPA would be an allowable deduction of a local authority.

Examples 10–13 illustrate how the proposed amendments would apply.

**Example 10: Interest incurred on money borrowed and on-lent to a CCTO**

The Drury District Council borrows \$50 million and on-lends \$30 million (60% of the \$50 million loan) to its CCTO (Drury Trading Company). The loan is for a fixed term and bears interest at 3% a year and there is no margin charged to the CCTO. The annual interest cost for Drury District Council is \$1.5 million.

The proposed amendment would limit the interest deduction for Drury District Council to \$900,000 (that is, 60% of the total \$1.5 million interest cost). The balance of the interest incurred by the Drury District Council would be non-deductible.

**Example 11: Interest incurred on money borrowed to acquire shares in a group company**

The Drury District Council borrows \$10 million for a fixed term at 3.5% a year. This loan is made to acquire shares in a new wholly owned company, Drury Administration Limited. This new company is a CCO but is not a CCTO.

The proposed amendment would deny a deduction for interest incurred by the Drury District Council on this loan because the group company (a CCO) is not a CCTO.

**Example 12: Annual finance costs for valuation change for financial arrangements**

The Drury District Council borrows \$48 million for a fixed term at 3.5% a year (floating rate). The Drury District Council enters into an interest rate hedge. The movements in the value of this hedge can result in a finance cost, which is treated as interest. None of this loan is on-lent to the Drury District Council's CCTOs.

The proposed amendment would deny a deduction for interest incurred by the Drury District Council on this loan because the money is not on-lent to a CCTO and the interest rate hedge does not relate to a CCTO.

**Example 13: Finance costs arising from a BPA calculation**

The Drury District Council borrows \$60 million for a fixed term at 3.3% a year (floating rate). Of this amount, \$40 million (two-thirds of the \$60 million loan) is on-lent to the Drury Trading Company (a CCTO). The Drury District Council enters into an interest rate hedge for the entire loan. At the expiry of the hedge, the BPA calculation results in a negative amount of \$100,000.

The proposed amendment would allow a deduction for two-thirds of \$100,000 as this proportion of the hedge relates to on-lending to a CCTO.

***Imputation credits attached to dividends***

Currently, a local authority is taxed on dividends derived from a CCO, a port company or an energy company. These dividends are generally received with maximum imputation credits attached.

Current tax rules allow some local authorities to satisfy their income tax liabilities on dividends without using the full amount of imputation credits attached to those dividends (for example, by using corporate gift deductions). This results in the local authority having excess imputation credits. The local authority can then convert the excess imputation credits



to a tax loss and offset the tax loss against the net income of its CCOs. This allows the local authority to shelter its CCOs from tax.

Converting imputation credits to a tax loss was part of the original design of the imputation system, as unused imputation credits are not refundable to the shareholder. The policy for converting unused imputation credits to a tax loss was to provide a mechanism for taxpayers in tax loss to carry forward the benefit of unused imputation credits to satisfy future income tax liabilities. It was not intended that an exempt shareholder would be able to convert unused imputation credits to a tax loss.

As the proposed amendments would include treating dividends from wholly-owned CCOs as exempt income, any imputation credits attached to such dividends would not give rise to a tax credit for the local authority.

However, local authorities may continue to derive dividends from CCOs that are not wholly owned. Imputation credits attached to these dividends can still give rise to the integrity concerns set out above if they can be converted to a tax loss. To address this integrity concern, the proposed amendments provide that local authorities would no longer be able to convert any unused imputation credits to a tax loss.

### ***Imputation credit accounts***

A local authority is not allowed to maintain an imputation credit account (ICA).<sup>3</sup> However, local authorities in consolidated tax groups can credit to the group's ICA imputation credits attached to dividends it derives from a CCO. These credits are then available for use by CCOs within the group.

The proposed amendments would mean that a local authority that is part of a consolidated group would not be able to make such credit entries to the group's ICA. This proposal would ensure that all local authorities are treated similarly for imputation credit purposes.

---

<sup>3</sup> Section OB 1(2)(c) of the Income Tax Act 2007.

## **FAIR DIVIDEND RATE FOREIGN CURRENCY HEDGES**

---

*(Clauses 71–78)*

### **Summary of proposed amendment**

Many investors who invest offshore enter into foreign currency hedges to protect themselves from fluctuations in the value of their offshore assets caused by exchange rate movements.

Differences in the tax treatment of the underlying assets and these foreign currency hedges can create a tax mismatch. This mismatch in treatment means that a hedge that is effective in removing the impact of unexpected currency fluctuations before tax ceases to be effective after tax.

The rules for hedging of foreign currency movement in Australian non-attributing shares and attributing FDR method interests (FDR FX hedges rules) were introduced from the beginning of the 2013–14 income year with the policy intent of eliminating this tax mismatch. The rules are optional and broadly allow a taxpayer to calculate tax on a foreign currency hedge on the same basis as the hedged offshore asset – thereby removing the tax mismatch.

There has been limited application of the FDR FX hedges rules by taxpayers since their introduction. This is because certain requirements in the rules imposing burdensome compliance costs for taxpayers with large numbers of hedges. Therefore, effective after-tax foreign currency hedging remains an ongoing issue for some taxpayers.

The proposed technical amendments to the FDR FX hedges rules would address this issue. The proposed amendments would improve their functionality from a practical perspective and reduce compliance costs for investors with large numbers of hedges.

### **Application date**

The proposed amendments would apply from 1 April 2022.

### **Key features**

The proposed amendments would:

- Modify the second formula for determining the extent to which foreign currency hedges can be subject to FDR treatment (known as FDR hedge portions).
- Introduce a de minimis threshold for non-eligible assets to ensure that immaterial foreign cash balances temporarily held do not reduce FDR hedge portions.
- Introduce an optional new method (known as the portfolio method) for determining FDR hedge portions to allow taxpayers with significant hedging activity to apply the rules from a practical perspective.
- Allow eligible hedges to have no NZD leg subject to certain requirements.
- Introduce an optional look-through rule to allow taxpayers who hedge indirectly owned eligible assets to apply the rules.

- Allow eligible hedges to continue to be subject to FDR treatment when there is a transfer of ownership of the assets of a fund or investor class.

Proposed remedial and technical amendments would also:

- Specify how the methods for determining FDR hedge portions apply to a hedge of hedge.
- Specify how the formula for calculating FDR income from eligible hedges is applied to hedges entered and settled within a valuation period.
- Clarify that all other income or expenditure arising from eligible hedges, besides the FDR amount, is exempt to the extent that FDR treatment applies.
- Amend the definition of non-eligible assets to exclude eligible hedges, and New Zealand securities listed on foreign exchanges and denominated in foreign currencies to the extent that no foreign currency hedges have been entered to hedge these assets.

## **Background**

### ***Foreign currency hedges***

When a person invests into an offshore asset, changes in the exchange rate can affect the value of the person's investment when it is converted back to New Zealand dollars (NZD). Therefore, many people who invest offshore enter into arrangements to protect themselves from exchange rate changes. These arrangements are referred to as *foreign currency hedges*. The idea is that changes in the hedge's value due to movements in the exchange rate offset changes in the value of the underlying foreign assets due to those same exchange rate movements.

### ***Tax mismatch***

A tax mismatch arises when a person hedges an investment taxed under the fair dividend rate (FDR) method. This is because, under the FDR method, changes in an asset's value are not taxed. Instead, FDR assets are taxed on a deemed dividend return of five percent of the asset's market value at the start of the period. Conversely, changes in a hedge's value are fully taxed under the financial arrangements rules. This mismatch in tax treatment means that a hedge that is effective in removing the impact of unexpected currency fluctuations before tax ceases to be effective after tax.

While taxpayers can attempt to hedge effectively on an after-tax basis, this is often not practical, especially when the taxpayer is taxed based on investors' marginal rates (for example, portfolio investment entities (PIEs) which are prevalent in the managed fund industry). It also increases the hedging transaction costs for an investor.

### ***FDR FX hedges rules***

The FDR FX hedges rules were introduced in 2013 with the policy intent of eliminating this mismatch in the tax treatment of foreign currency hedges and hedged offshore assets. The rules are optional and allow a taxpayer to calculate tax on a foreign currency hedge on the same basis as the hedged offshore asset – by imputing taxable income of five percent of a hedge's opening market value.

The FDR FX hedges rules were designed to ensure that FDR treatment was not available for speculative instruments or hedges of non-eligible assets, and also to prevent manipulation. These risks were addressed by including appropriate restrictions in the regime. However, these restrictions impose burdensome compliance costs on taxpayers with large numbers of hedges which have resulted in the rules being impractical to apply. Therefore, effective after-tax foreign currency hedging remains an ongoing issue for some taxpayers.

## Detailed analysis

Proposed technical amendments to the FDR FX hedges rules would reduce compliance costs and improve the functionality of the rules from a practical perspective. The specific issues with the rules and the proposed amendments are detailed below.

### *Modification to second hedge-by-hedge formula for calculating FDR hedge portions (clause 74(1), (8) and (10))*

The FDR FX hedges rules currently include two alternative formulae to determine the maximum fair dividend rate hedge portion (FDR hedge portion) on a hedge-by-hedge basis that a taxpayer can choose from. These formulae ensure that the amount of a taxpayer's eligible hedges that can be subject to FDR treatment does not exceed the value of their hedged eligible assets.

However, the application of the second formula in current sections EM 5(6)–EM 5(10) always results in an FDR hedge portion of less than a 100% when a taxpayer holds non-eligible assets, even when those non-eligible assets are already fully hedged.

#### **Example 14: Fagan**

On 2 August 202x, *Fagan Asset Management Fund (Fagan)* has a portfolio of:

- US\$55,000 of shares in US-based companies (eligible assets, worth NZ\$70,000)
- US\$20,000 of US bonds (non-eligible assets, worth NZ\$30,000)
- A hedge of USD to NZD with a foreign amount hedged of US\$20,000 (equivalent to NZ\$30,000). This hedge has an FDR hedge portion of zero.

On 2 August 202x, Fagan enters into an eligible hedge for US dollars with a foreign amount hedged of US\$55,000 (equivalent to NZ\$70,000). Applying the current second hedge-by-hedge formula to this hedge results in a maximum FDR hedge portion of the lower of the following two formula:

$$\text{First formula} \quad 1 - \frac{\text{NZ\$30,000}}{\text{NZ\$100,000}} = 70\%$$

$$\text{Second formula} \quad \frac{(1.05 \times \text{NZ\$70,000} - 0)}{\text{NZ\$70,000}} = 105\%$$

This means that the maximum FDR hedge portion that can be applied to the hedge of US\$55,000 is 70% even though *Fagan's* non-eligible assets are already fully hedged by the hedge on hand of US\$20,000.

To address this issue, the proposed amendment would modify the second hedge-by-hedge formula for calculating FDR hedge portions to ensure its application does not always result in an FDR hedge portion of less than 100% when a taxpayer's non-eligible assets are already fully hedged.

The proposed new formula can be broken down into three steps.

The first step would be to calculate the apportioned current hedge amount. The purpose of this step would be to allocate a hedge to non-eligible assets first which is the policy intention of the second formula.

The *apportioned current hedge amount* would be one of the following amounts:

- If the calculation hedge is not a hedge of a hedge,<sup>4</sup> or is a hedge of a hedge and the second bullet point below does not apply, the amount is the lesser of the following amounts:
  - the amount of foreign currency hedged by the calculation hedge, and
  - the amount of foreign currency that is hedged by a person’s hedges including the calculation hedge less the amount of foreign currency that is hedged by a person’s FDR hedge portions excluding the calculation hedge less the total market value of a person’s non-eligible assets, treating a negative result as zero.
- The negative of the amount of foreign currency that is hedged by a person’s FDR hedge portions excluding the calculation hedge, if:
  - the calculation hedge is a hedge of a hedge, and
  - the amount of foreign currency that is hedged by a person’s FDR hedge portions excluding the calculation hedge plus the calculation hedge equals less than zero.

If the apportioned current hedge amount is zero, the FDR hedge portion would be zero and no further action would be required.

The second step would be to calculate the FDR gross amount. This is the portion of the apportioned current hedge amount that hedges eligible assets and is therefore eligible for FDR treatment.

The *FDR gross amount* would be the lesser of 1 and the amount resulting from the following formula:

$$\frac{(1.05 \times \text{eligible currency assets} - \text{FDR hedges amount})}{\text{apportioned current hedge amount}}$$

Where:

- **Eligible currency assets** would be the total market value of a person’s eligible assets owned directly and, if the person chooses and is a qualifying hedge fund (described below), their interest in the eligible assets that are owned by a multi-rate PIE in which the person invests, converted to NZD.
- **FDR hedges amount** would be the amount of foreign currency hedged by a person’s fair dividend rate hedge portions but excluding the portion for the calculation hedge.
- **Apportioned current hedge amount** would be the amount calculated for the first step.

If the denominator is zero, the formula result should be treated as zero.

---

<sup>4</sup> A hedge of a hedge is a hedge that effectively cancels out another hedge of a foreign currency to NZD.



**Example 16**

van der Clark Wealth Partners Fund (van der Clark) has a portfolio of:

- US\$100,000 of shares in US-based companies (eligible assets)
- US\$40,00 of US bonds (non-eligible assets)
- US\$5,000 of US cash (non-eligible assets)

As a result of the 5% de minimis threshold for cash assets, the value of van der Clark's non-eligible assets would be US\$40,000 (being US\$45,000 less US\$5,000) for the purposes of the rules.

***Optional portfolio method for calculating FDR hedge portions (clauses 71(1), 73, 74(3), 75, and 77)***

The current formulae for determining FDR hedge portions must be applied at the time an eligible hedge is entered into, and the portion calculated is applied for the life of a hedge. Where taxpayers hold a significant number of hedges at any point in time and turnover hedges regularly, the requirement to apply the rules on a hedge-by-hedge basis can impose burdensome compliance costs which result in the rules being impractical to apply.

To address this issue, the proposed amendment would introduce a new optional portfolio method for calculating FDR hedge portions for eligible hedges. This method would sit alongside the two existing formulae for calculating FDR hedge portions on a hedge-by-hedge basis, and taxpayers would have the option of selecting their preferred method (subject to eligibility criteria detailed below).

The requirements under section EM 7 would not apply to taxpayers using the portfolio method. This is because FDR hedge portions for all eligible hedges would be reset at the start of every period.

***Eligibility criteria and elections***

Only taxpayers that are daily unit valuers for the purposes of section EX 53 would be able to elect to use the portfolio method. This election can be made at any time. However, once an election to use this method has been made, taxpayers would be required to apply the portfolio method to all existing eligible hedges on hand (regardless of whether they are subject to an existing hedge-by-hedge method) and any hedges entered into post-election for a minimum of four years.

***Period***

Taxpayers would be able to elect their own periodic basis for calculating FDR hedge portions, up to a maximum period of one month. However, taxpayers would not be allowed to alter the periodic basis for calculating FDR hedge portions for four years.

***Portfolio FDR hedge portion***

Under this method the FDR hedge portion would be calculated at the start of each period and applied to the entire portfolio of eligible hedges for that period.

Where a taxpayer enters into a new eligible hedge within a period, the FDR hedge portion calculated for the portfolio at the start of the period would apply to that hedge until the end

of the period, at which point the FDR hedge portion calculated for the portfolio for the next period applies.

### *Formulae*

The approach for calculating FDR hedge portions under this method would involve two formulae, with the portfolio FDR hedge portion being set at the lower of the two (unlike the existing hedge-by-hedge formulae which calculate the maximum).

The first formula would be:

$$1 - \frac{\text{non-eligible assets}}{\text{portfolio hedges amount}}$$

Where:

- **Non-eligible assets** would be the total market value of a taxpayer's foreign currency assets excluding eligible assets, de minimis cash assets, eligible hedges and certain New Zealand securities denominated in a foreign currency, converted to NZD.
- **Portfolio hedges amount** would be the total amount of foreign currency that is hedged by a taxpayer's hedges, converted to NZD.

The second formula would be:

$$\frac{1.05 \times \text{eligible currency assets}}{\text{portfolio hedges amount}}$$

Where:

- **Eligible currency assets** would be the market value of a taxpayer's eligible assets owned directly and, if the taxpayer is a qualifying hedge fund (described below) and chooses to, their interests in the eligible assets held by a multi rate PIE in which the taxpayer invests, converted to NZD.
- **Portfolio hedges amount** would refer to the total amount of foreign currency that is hedged by a taxpayer's hedges, converted to NZD.



### Example 17

Gekko Investments Fund (Gekko) is a daily unit valuer who elects to use the portfolio method and chooses a periodic basis of one month.

On 1 September 202x, Gekko holds:

- £25,000 of shares in UK-based companies (eligible assets, worth NZ\$50,000)
- £10,000 of UK bonds (non-eligible assets, worth NZ\$20,000)
- Hedges of GBP to NZD with a foreign amount hedged of UK£30,000 (equivalent to NZ\$60,000).

Gekko's FDR hedge portion for September 202x would be calculated as follows:

$$\text{First formula} \quad 1 - \frac{\text{NZ\$20,000}}{\text{NZ\$60,000}} = 67\%$$

$$\text{Second formula} \quad \frac{(\text{NZ\$50,000} \times 1.05)}{\text{NZ\$60,000}} = 88\%$$

The FDR hedge portion for Gekko's hedges for September 202x would be 67% (being the lower of the result of the two formulae). This FDR hedge portion would be applied to **all** hedges on hand at the start of the month as well as new hedges or hedges of hedges entered into within September 202x regardless of any changes in the holdings of eligible or non-eligible assets.

On 1 October 202x, Gekko holds:

- UK£15,000 of shares in UK-based companies (eligible assets, worth NZ\$30,000)
- UK£30,000 of UK bonds (non-eligible assets, worth NZ\$60,000)
- Hedges of GBP to NZD with a foreign amount hedged of £40,000 (equivalent to NZ\$80,000).

Gekko's FDR hedge portion at the start of October 202x would be calculated as follows:

$$\text{First formula} \quad 1 - \frac{\text{NZ\$60,000}}{\text{NZ\$80,000}} = 25\%$$

$$\text{Second formula} \quad \frac{(\text{NZ\$30,000} \times 1.05)}{\text{NZ\$80,000}} = 39\%$$

The portfolio hedge portion for Gekko for October 202x would be 25% (being the lower of the result of the two formulae). This portfolio FDR hedge portion would be applied to **all** hedges on hand at the start of the month as well as new hedges or hedges of hedges entered into within month two regardless of any changes in the holdings of eligible or non-eligible assets.

### ***Eligible hedge requirements – one leg in NZD (clause 72(1) and (2))***

Eligible hedges are currently required to have one “leg” in NZD (that is, hedge one foreign currency back to NZD). Often taxpayers with large portfolios of hedges rebalance their hedging position of eligible assets denominated in two foreign currencies to NZD, by hedging one foreign currency to the other – that is, entering a hedge with no NZD leg. These hedges are entered into to eliminate foreign currency risk in relation to eligible assets but are currently not eligible for FDR treatment.

The proposed amendments would allow eligible hedges to have no NZD leg provided these hedges are entered into to adjust the hedging position of existing hedges on hand that have one leg in NZD.

This proposed eligible hedge requirement would only be extended to taxpayers applying the second formula in the hedge-by-hedge method or the new portfolio method for calculating FDR hedge portions. This change would not apply when the first formula in the hedge-by-hedge method is used because amounts must be calculated in the calculation hedge's foreign currency for the purposes of this formula, rather than converted to NZD, and this is not practical where a hedge has two legs in a foreign currency.

***Optional look-through rule (clauses 74(7), 74(10), 75 and 78)***

Taxpayers commonly invest into eligible assets indirectly through other funds and may hedge their foreign currency exposure in relation to these indirectly owned eligible assets. However, only directly owned eligible assets are treated as eligible assets for the purposes of the FDR FX hedges rules. The result is that hedges of indirectly held assets are not eligible for FDR treatment.

To address this issue, the proposed amendments would introduce an optional look-through rule to allow certain funds to include their interest in eligible assets held by a multi-rate PIE in which they invest in their calculation of eligible assets.

This look-through rule would only be available to a “qualifying hedge fund”, which is defined as a zero-rate investor in a multi-rate PIE if the multi-rate PIE attributes income from eligible assets to the zero-rate investor.

In applying this new look-through rule, the qualifying hedge fund would need to determine the value of their interest in eligible assets held in the multi-rate PIE by reference to the proportion of the total units held in the PIE. The zero-rate investor would need to have access to sufficient information from the multi-rate PIE to choose to apply this optional rule and comply with the requirements.

***Transfer of eligible hedges (clauses 72(3), 73, 74(4), 74(6) and 74(10))***

The application of the FDR FX hedges rules to eligible hedges that are transferred between funds or sub funds is currently unclear. This is because under section EM 3 an eligible hedge is required to have a fair value of zero when first entered into. Also, under section EM 4, an election to apply the rules must be made before a hedge is first entered into, and under section EM 5, FDR hedge portion calculations must be performed when a hedge is first entered into.

The proposed amendments would address this issue by amending the definition of an eligible hedge to include a hedge that is entered into or *acquired* at its fair value. Elections for the rules to apply would also be allowed before a hedge is first entered into or *acquired* and FDR hedge portion calculations would be allowed to be performed when an eligible hedge is first entered into or *acquired*.

***Remedial amendments***

***Hedge of a hedge (clauses 74(2), 74(4), 74(5), 74(9) and 74(10))***

A hedge of a hedge is currently eligible for FDR treatment.<sup>5</sup> However, the methods for calculating FDR hedge portions do not work as intended when applied to a hedge of a hedge.

---

<sup>5</sup> A hedge of a hedge is a hedge that effectively cancels out another hedge of a foreign currency to NZD.

The general policy principle is that the FDR method can be applied to eligible hedges that hedge a maximum of 105% of the currency risk for eligible assets. When the formulae in section EM 5 are applied to a hedge of a hedge however, the FDR hedge portion will be the amount that reduces the combined FDR hedge portions for all hedges, including the hedge of a hedge, to a minimum of 105%. From a policy perspective, the hedge of a hedge should be allowed to reduce the combined FDR hedge portions below 105%.

**Example 18: Dern**

On 2 August 202x, Dern Capital Solutions Fund (Dern) has a portfolio of:

- £45,000 of shares in UK-based companies (eligible assets, worth NZ\$90,000)
- £5,000 of UK bonds (non-eligible assets, worth NZ\$10,000)

Dern currently has one foreign currency hedge for UK pounds with a foreign amount hedged of £50,000 (equivalent to NZ\$100,000) and an FDR hedge portion of 90% (calculated under the first formula in the hedge-by-hedge method). Therefore, the total FDR hedge portions coverage of eligible assets is 100%.

On 10 August 202x, the value of Dern’s UK shares drops to £40,000 (NZ\$80,000). In order to adjust their foreign currency hedge exposure as result of this drop, Dern enters into a hedge of a hedge on 10 August 202x, for £5,000 (NZ\$10,000). Applying the first formula in the hedge-by-hedge method, the **maximum** FDR hedge portion for this hedge of a hedge would be:

$$\frac{1.05 \times (\pounds40,000 + \pounds0) - (\pounds50,000 \times 0.90)}{-\pounds5,000} = 60\%$$

A maximum FDR hedge portion of 60% for the hedge of a hedge would result in the total FDR hedge portions coverage of eligible assets being a **minimum** of 105%.

To address this issue, the proposed amendments would mean that the formulae in section EM 5 should identify the **minimum** FDR hedge portion rather than the maximum when applied to a hedge of a hedge, with a negative result treated as a minimum of 0%.

Taxpayers could choose to apply an FDR hedge portion to the hedge of a hedge between the minimum identified in the formulae and 100%, provided their combined FDR hedge portions do not fall below zero.

When applying the formulae for calculating FDR hedge portions to a hedge that is a hedge of a hedge, the hedge should be treated as a negative amount.

**Example 19**

Assuming the same as for example 18, application of the first hedge-by-hedge method calculation would instead identify a **minimum** FDR hedge portion of 60% for the hedge of hedge for £5,000. This would result in the total FDR hedge portions coverage of eligible assets being a **maximum** of 105%.

*Hedges entered and settled within a valuation period (clause 76)*

Section EM 6 calculates the FDR income or expenditure from eligible hedges by reference to the hedges’ opening market value at the start of every valuation period. Eligible hedges entered into and settled within a valuation period do not have an opening market value and as a result are not subject to this calculation. The result being that any gain (or loss) on these hedges is not subject to either FDR treatment or the FA rules.

The proposed changes to the formula in section EM 6 would address this by including the net gain or loss on eligible hedges entered and settled within the preceding valuation period.

The proposed new formula would be:

$$\frac{(\text{FDR portions' value} + \text{period gain} - \text{period loss}) \times 0.05 \times \text{valuation period}}{\text{days in the year}}$$

Where:

- **Period gain** would be the net gain multiplied by the FDR hedge portion for relevant eligible hedges that are entered into and settled within the preceding valuation period.
- **Period loss** would be the net loss multiplied by the FDR hedge portion for relevant eligible hedges that are entered into and settled within the preceding valuation period.

#### Example 20

Sterling Cooper Fund has a one-month valuation period. Its hedging activity during March 202x is:

- On 4 March 202x, it enters into an eligible hedge for US\$100,000 (equivalent to NZ\$140,000 at acquisition). This hedge has an FDR hedge portion of 50%.
- On 15 March 202x, it enters into an eligible hedge for US\$50,000 (equivalent to NZ\$75,000 at acquisition). This hedge has an FDR hedge portion of 100%.
- On 27 March 202x, the hedge for US\$50,000 is settled. At settlement, US\$50,000 is equivalent to NZ\$70,000.
- At the end of 31 March 202x, the hedge entered into on 4 March 202x is still on hand and US\$100,000 is equivalent to NZ\$125,000. There are no other hedges on hand.

Applying the proposed amendment to the formula in section EM 6, Sterling Cooper's FDR income from its eligible hedges on 1 April 202x would be:

$$\frac{((\text{NZ\$}125,000 \times 50\%)) + 0 - \text{NZ\$}5,000) \times 0.05 \times 31}{365} = \$244$$

Period gain is zero on 1 April 202x because there was no net gain on the hedge of US\$50,000 that was entered and settled within the preceding valuation period.

Period loss is NZ\$5,000 on 1 April 202x because there was a net loss of \$5,000 (being (NZ\$70,000 – NZ\$75,000) × the 100% FDR hedge portion) on the hedge of US\$50,000 that was entered and settled within the preceding valuation period.

#### *Income or expenditure under other provisions (clauses 71(2) and 73)*

Under the FDR FX hedges rules no income or expenditure from eligible hedges arises under the FA rules to the extent to which the hedges are subject to FDR treatment. However, the rules do not explicitly state that no income or expenditure arises from eligible hedges under other provisions to the extent that FDR treatment applies. This opens the theoretical possibility of double tax or double deductions.

The proposed amendments would explicitly clarify that no other income or expenditure arises from eligible hedges to the extent that FDR treatment applies.

#### *Definition of non-eligible assets (clauses 74(11) and 78(1))*

The market value of foreign currency hedges is included within the current definition of non-eligible currency assets.

The current definition of non-eligible assets also includes New Zealand securities listed on foreign exchanges that are denominated in foreign currencies. Although these assets are

denominated in a foreign currency, any hedges entered into in relation to them are not eligible for FDR treatment on the basis that these securities are naturally hedged back to NZD. In essence, they are more akin to NZD securities than foreign currency securities and therefore should not be within the definition of non-eligible assets – which is intended to identify foreign investments that are not subject to FDR treatment.

Including these amounts in the definition of non-eligible assets has a distortionary effect on FDR hedge portion calculations, therefore proposed changes would exclude eligible foreign currency hedges from the definition of non-eligible assets, as well as New Zealand securities listed on foreign exchanges denominated in foreign currencies, to the extent that no foreign currency hedge has been entered into to hedge these assets, from the definition of non-eligible assets.

## **USE OF TAX POOLING TO SATISFY A BACKDATED TAX LIABILITY**

---

*(Clause 125)*

### **Summary of proposed amendment**

The proposed amendment would enable taxpayers to use tax pooling to satisfy a liability arising from a voluntary disclosure where there is no existing assessment.

### **Application date**

The proposed amendment would apply from the date of enactment.

### **Background**

Under current settings, tax pooling cannot be used where there is no existing assessment or quantified obligation. The only exception is certain voluntary disclosures for income tax and resident withholding tax (RWT) where no prior return was filed, and the return was provided as part of the voluntary disclosure. In these situations, use of tax pooling is subject to a Commissioner's discretion measured against specific legislative criteria.

In some circumstances, a taxpayer may have unintentionally not filed a tax return for a particular tax type and tax period. For example, a small business may be unaware that an employee benefit it provides is subject to fringe benefit tax and so does not provide a return. Tax pooling will be available where the new liability did not arise as a result of a choice by the person not to comply with the person's obligations under the Inland Revenue Acts or as a result of a failure by the person to take reasonable care to comply with those obligations.

### **Key features**

Under the proposed amendment, a taxpayer would be able to use tax pooling, and thereby mitigate their exposure to UOMI, for voluntary declarations related to tax types other than RWT and income tax. The tax types that would be covered are tax paid or payable under the PAYE rules, ESCT rules, RSCT rules, NRWT rules, GST, FBT, income tax, further income tax, and imputation penalty tax.

This change would also include these proposed measures to ensure that the integrity of the tax system is not undermined through the wilful non-filing of returns:

- The taxpayer must make a voluntary disclosure to file the original return and generate an original assessment or obligation before Inland Revenue has made any contact with the taxpayer or their agent.
- This would be available where the new liability did not arise as a result of a choice by the person not to comply with the person's obligations under the Inland Revenue Acts or as a result of a failure by the person to take reasonable care to comply with those obligations.
- The voluntary disclosure must be made within a reasonable time frame of the taxpayer or their agent becoming aware of the error, with "reasonable time frame" to be defined by guidance issued by the Commissioner of Inland Revenue or by an Order in Council.

## OVERSEAS DONEE STATUS – SECTION YZ 5 AND SCHEDULE 32

---

*(Clauses 131 and 133)*

### **Summary of proposed amendment**

The proposed amendments to the Income Tax Act 2007 (ITA) would add 11 charities to the list of donee organisations in schedule 32 of the ITA and remove others that have ceased to operate in New Zealand. Proposed changes would also update the name of a current organisation on the list and extend the donee status of NZ Memorial Museum Trust – Le Quesnoy.

### **Application date**

These application dates would apply for the proposed changes:

- The proposed amendments adding the eleven new additions to the schedule would apply from 1 April 2021 for donations made in the 2021–22 or later income years. The amendment extending the NZ Memorial Museum – Le Quesnoy’s overseas donee status would also apply from 1 April 2021.
- The proposed removals would apply from the date of enactment.
- The proposed maintenance change would apply from 4 May 2020.

### **Key features**

The proposed amendments would:

- Add 11 charitable organisations to schedule 32 of the ITA. Donors to these charities would be eligible for tax benefits on their donations.
- Extend overseas donee status for the NZ Memorial Museum Trust – Le Quesnoy to 31 March 2025.
- Remove nine organisations from the schedule. Inland Revenue records show these organisations have ceased operations and fundraising in New Zealand.

A proposed maintenance change would update the reference to UN Women Aotearoa New Zealand Incorporated.

### **Background**

Donors to organisations listed in schedule 32 are entitled as individual taxpayers, to a tax credit of 33 $\frac{1}{3}$ % of the monetary amount donated, up to the amount of their taxable income. Companies and Māori authorities may claim a deduction for donations up to the level of their net income. Charities that apply funds towards purposes that are mostly outside New Zealand must be listed in schedule 32 of the Income Tax Act 2007 before donors become eligible for these tax benefits.

## **Detailed analysis**

### ***Additions to the list of donee organisations***

The proposed 11 charitable organisations that would be added to schedule 32 are engaged in the following activities:

#### *Community Transformation Trust*

Community Transformation works in partnership with communities in developing countries to improve economic outcomes and the relief of poverty. It is currently supporting projects that improve water quality and land use in South Sulawesi, Indonesia, in partnership with Global Hope Network International.

#### *Firefly Children's Home Charitable Trust*

Firefly Children's Home operates in partnership with PA Nepal (Prisoners Assistance Nepal, a registered Nepali charity) and supports orphaned or abandoned children including the children of prisoners. Firefly's purposes are directed towards relieving poverty and ensuring those in care receive adequate education and medical attention.

#### *Hadassah Medical Relief Association of New Zealand*

The Hadassah New Zealand Association provides financial support to Hadassah International, which operates several hospitals in Jerusalem. Hadassah International provides treatment to all people irrespective of race or religious views. Hadassah International also has an international relief focus within socio-economically deprived areas of the Middle East and carries out medical relief missions in Africa. It also provides international assistance by providing additional medical capacity in response to natural disasters.

#### *Hands Across the Water New Zealand Trust*

Hands Across the Water New Zealand Trust works in partnership with Hands Across the Water Australia to provide education and training opportunities for orphaned, abandoned, or homeless children in Thailand. It supports six homes in Thailand and has around 350 children in care. In addition to the care provided by the homes, Hands Across the Water provides tuition in English and supports former residents seeking higher education.

#### *Institute for Indian Mother and Child Aotearoa Charitable Trust*

The Institute for Indian Mother and Child Aotearoa provides sponsorship support to children under the care of the Institute for Indian Mother and Child, based in Kolkata, India. The Kolkata organisation mainly provides medical support to the poor and destitute; it has also built schooling facilities in the poorest villages to provide education for primary and secondary school-aged children.

#### *Medic to Medic*

Medic to Medic is a New Zealand sister charity to similarly named charities in the United Kingdom and the United States. The purpose of Medic to Medic is to increase medical and healthcare professional capacity in developing countries by providing scholarships to students at risk of dropping out of their training due to poverty.



### *Missio Benevolent Society*

Missio Benevolent Society is the humanitarian aid arm of the New Zealand office providing for the Pontifical Missions Society. Missio's activities are directed toward the relief of poverty and advancing education in Oceania, Africa, Asia and South America.

### *Prabh Aasra Trust*

Prabh Aasra Trust raises funds to support its Indian counterpart Prabh Aasra, which provides care and medical treatment to the homeless and destitute in North India.

### *Reemi Charitable Trust*

Reemi Charitable Trust is a social enterprise whose activities are directed at alleviating period poverty in developing countries. It is currently active in Bangladesh and seeks to improve physical and mental health outcomes for women through education and supplying culturally appropriate products such as self-sterilising underwear and laundry bags.

### *Talalelei Life Futures Fund*

Talalelei Life Futures Fund provides yearly scholarships to support academic high performers to obtain tertiary qualifications in Samoa.

### *YWAM Ships Aotearoa Limited*

Using a specifically equipped medical aid ship, YWAM Ships Aotearoa undertakes health and education work in remote and isolated communities throughout the Pacific Islands, Papua New Guinea, and the Solomon Islands. YWAM Ships provides a range of medical services to these communities including eye care, dental care, and immunisation and paediatrics. It also carries out developmental projects for those communities, such as water sanitation, to improve and maintain overall health outcomes.

### ***Removals from the list of donee organisations on schedule 32***

As part of Inland Revenue's stewardship of overseas donee status Inland Revenue has examined what information it has on record about the charities that have overseas donee status. This work is ongoing and complements New Zealand's regulatory framework to prevent overseas financing of terrorism and extremism.

The proposed changes would remove the following organisations from schedule 32:

- Books for Cambodia
- Channel 2 Cyclone Aid for Samoa
- Cyclone Ofa Relief Fund
- Cyclone Val Relief Fund
- Kyrgyzstan New Zealand Rural Trust
- L Women of Africa Fund
- The Band Aid Box
- The Serious Road Trip Charitable Trust
- The Sir Walter Nash Vietnam Appeal

### ***NZ Memorial Museum Trust – Le Quesnoy***

The New Zealand Memorial Museum Trust – Le Quesnoy was given donee status for a time-limited period with effect from 1 April 2018. The Trust's donee status was to end during March 2022.

The Trust's purposes are to create a museum in Le Quesnoy, France, as a memorial to New Zealand's participation in and contribution to the First World War. The museum proposes to be a place to provide information and learning resources to visitors about the service of New Zealanders during that conflict.

Fundraising for the project, and wider commissioning activities relating to the museum site in France has been negatively affected by COVID-19. Recognising the impact of COVID-19 on the Trust, the Government has agreed to extend the Trust's overseas donee status to 31 March 2025.

### ***Maintenance change – UN Women Aotearoa New Zealand Incorporated***

The UN Women National Committee Aotearoa New Zealand Incorporated was given overseas donee status with effect from 1 April 2019. The proposed maintenance change would update the reference to UN Women Aotearoa New Zealand Incorporated with effect from 4 May 2020, the date the organisation changed its name.

---

# GST remedials

---



## MODERNISING INFORMATION REQUIREMENTS FOR GST

---

*(Clauses 5(1), 9, 12, 19, 21(1)–(3) and 21(9)–(10), 24, 26–34, 36, 38–40, and 42–44)*

### Summary of proposed amendments

The proposed amendments seek to reform the way in which the GST system interfaces with 21<sup>st</sup> century business record-keeping without changing the process of accounting for GST for each taxable period.

The proposed changes mainly relate to:

- setting out relationships between the different parts of the Goods and Services Tax Act 1985 (GST Act)
- supply information (including GST charged on the supply), which is described in two new terms supply information and taxable supply information (currently, this information is contained in the defined terms invoice and tax invoice)
- how supply information is used to support input tax deductions
- adjustment information, which is described in a new term supply correction information (currently required to be set out in a credit note or a debit note)
- buyer-created invoices and shared processes, which will rely on taxable supply information
- payment receipts, which are treated as taxable supply information, for example, for low value supplies not exceeding \$200
- consequentially updating terminology in a number of information and recordkeeping provisions, and
- providing consistency with the provision of information rules in subpart 2 of the Tax Administration Act 1994 (TAA).

The proposed amendments rationalise supply information provisions in the GST Act. The rationalisation is to allow supply information to be created and retained in business record-keeping systems rather than requiring the creation and retention of a statutorily prescribed document (for example, tax invoice, credit note, debit note).

The proposed changes permit the form and manner of creating, providing and retaining supply information to be determined by registered persons, including GST groups and companies electing to use the supplier group provisions. The proposals are also consistent with e-invoicing initiatives and electronic recordkeeping.

In addition, the proposed amendments would not disturb the processes for calculating and paying GST for each taxable period. This seamless transition arises because the nature of supply information required to support these processes remain unchanged. Only the form of recording, retaining and providing supply information is proposed to change.

## **Application date**

The proposed amendments would apply for taxable periods beginning on or after the date of enactment.

## **Key features**

### ***Supply information***

#### *Proposed requirements*

Under proposed amendments the current provisions for tax invoices would be replaced with a list of information that supports the integrity of the GST system. The proposed amendments also would repeal the simplified tax invoice for taxable supplies having a value not exceeding \$1,000. Otherwise, the list of supply information that would be retained by the supplier and provided to a registered recipient remains unchanged.

This proposed list of information would be set out in two new proposed terms (*supply information* and the *taxable supply information*) neither of which would require the information to be provided or retained in any particular format in the same way as a tax invoice format is prescribed in current law. Other relevant new terms proposed are *GST trade name* and *recipient details*. The provision of information rules in the TAA will continue to apply to this information.

A minor change to the current law for information requirements relates to the supplier's obligation to provide supply information for a taxable supply to a registered recipient at the time of supply, only on request.

The proposed amendments would require the supplier to provide a registered recipient with the taxable supply information, which is consistent with commercial practice. A copy of a taxable supply information can be obtained by a registered recipient if the original taxable supply information has been lost or become corrupted.

An un-registered recipient who later becomes registered for GST, can ask for relevant supply information from the supplier (if information remains available). This ensures that supply information can be available to the recipient to support input tax deductions for secondhand goods.

Proposed changes to the rules relating to supply information for GST groups and supplier groups would ensure consistency with these general changes. These proposed amendments are discussed later in a separate commentary item "GST groups".

### ***Correcting supply information***

Currently a registered person may correct taxable supply information for a cancellation of a taxable supply, or an increase or decrease in the GST amount previously recorded.

The amendments propose that a registered person may also correct other incorrect supply information previously recorded.

This proposed list of information would be termed *supply correction information*. It is also proposed that it would no longer be necessary to have separate processes for credit or debit adjustments.

The proposed amendments would also allow other errors in taxable supply information to be corrected under this process. It is anticipated that the Commissioner will publish guidelines for this changed process.

### ***Copies of supply information***

If a copy of a taxable supply information or a supply correction information is requested, it would no longer be mandatory to require this information to be marked “copy only”.

### ***Buyer-created taxable supply information***

Under current law, GST-registered buyers must obtain Inland Revenue’s prior approval to issue buyer-created tax invoices. The proposed amendments would remove the requirement to have Commissioner pre-approval and instead require an agreement between the supplier and recipient (both must be registered persons) that is recorded by both parties.

This agreement must record:

- that only the recipient will create the taxable supply information and that the recipient will provide that information to the supplier, and
- the reasons for entering into the agreement.

If the Commissioner considers the agreement is inconsistent with legislative parameters, the Commissioner may treat the agreement as invalid.

### ***Shared tax invoices and supplier groups***

The proposed amendments would clarify that a group of registered persons may use the shared invoice process, provided none of those entities are part of a GST registered group. The registered person that is currently termed the principal supplier for a shared tax invoice, is proposed to be an agent for each registered person that is a party to that agreement.

Companies choosing to use the shared invoice process would be required to document in an agreement:

- the reasons for adopting the shared invoice process
- acceptance of joint and several liability for GST obligations for each taxable supply
- which registered person will create taxable supply information (no change)
- certain identifying GST information for each party to the agreement, and
- this type of agreement will also be subject to normal assurance processes, and if the Commissioner considers the agreement is inconsistent with legislative parameters, the Commissioner may treat the agreement as invalid.

### ***Recipient obligation to have business records that supports input tax deductions***

The amendments propose that, rather than relying on a formal “tax invoice”, a wider set of ordinary business-to-business information, including electronic information, could be able to be used to support GST output tax and input tax.

This proposal will be supported by a proposal to introduce a strict liability penalty for claiming input tax more than once for the same taxable supply. The proposed strict liability

penalty replaces a knowledge offence penalty that applies to a supplier who has issued more than one tax invoice for the same supply

## Background

In broad terms, the GST system operates as follows:

- Contract law determines whether a supply of goods or services occurs.
- Supplies of goods or services by registered persons are levied with GST either at the standard rate (15%) or at a zero rate (exports, sale as a going concern, some land transactions). These supplies are known as taxable supplies.
- Registered persons must file a self-assessed GST return for each taxable period (generally 1 month, 2-monthly, or 6-monthly).
- The GST payable or refundable for a taxable period is calculated from:
  - the difference between total output tax charged on taxable supplies made to customers and total input tax borne on business costs (assets and expenses), and
  - adjustments for second-hand good (input tax), and for partial private use of business assets (output tax) or partial business use of private assets (input tax).

The integrity of the GST system is supported by prescribed information about taxable supplies (supply information), which in most cases is contained in a tax invoice. For a low value supply (\$50 or less), the necessary information is usually contained in a receipt for the transaction. Supply information may also include subsequent adjustments to the original supply information using credit notes and debit notes, and for low value taxable supplies, payment receipts.

The form of the tax invoice is based on paper-based recordkeeping systems and this has not altered since GST was introduced. The information required to be included in the tax invoice relates to the identities of the supplier and recipient, the nature of the goods or services supplied, and the GST levied on that supply. In this commentary this is referred to as supply information. A tax invoice is required for all taxable supplies having a value greater than \$50.

A GST issues paper, published in February 2020,<sup>6</sup> sought feedback on proposals to address integrity risks mainly relating to compliance and administration costs because:

- the standard requirements for tax invoices, which support the integrity of the GST system, have not changed very much since 1986
- vast changes in business practices relating to transactional information and the use of technology have occurred since the introduction of GST, and
- the New Zealand and Australian governments are working together to facilitate electronic invoicing (e-invoicing) to allow data exchange to be used in place of traditional invoices.

---

<sup>6</sup> Inland Revenue. (February 2020). *GST policy issues – an officials' issues paper*. <https://taxpolicy.ird.govt.nz/publications/2020/2020-ip-gst-issues>



## Detailed analysis

### *Supply information*

#### *Current requirements*

Under current law, a registered person making a taxable supply is, when requested, required to provide a tax invoice to a registered person that contains prescribed disclosures for that supply.

The manner in which a registered person provides this information to the recipient is governed by section 14B and related provisions in Subpart 2D of the Tax Administration Act 1994 (provision of information rules). In broad terms, those provisions require that information relating to a supply transaction can be provided in a number of ways. For supply information provided electronically, that information must comply with certain legislative provisions of contract law.<sup>7</sup>

#### *Proposed requirements*

The proposed amendments replace current provisions relating a tax invoice with a list of information that supports the integrity of the GST system. The proposed amendments also would repeal the simplified tax invoice for taxable supplies having a value not exceeding \$1,000. Submissions on the GST issues paper indicated that in the modern record-keeping environment, the simplified tax invoice would not be required.

The only other change of note to current information requirements, is that a registered supplier must keep a record of the quantity or volume of goods or services supplied but this information would no longer be required to be provided to the recipient of a taxable supply for GST purposes.

Otherwise, the list of supply information that would be retained by the supplier and provided to a registered recipient remains unchanged. This list of information is proposed to be set out in two new terms (*supply information* and the *taxable supply information*) neither of which require the information to be provided or retained in any particular format in the same way as a tax invoice format is prescribed in current law. Other relevant terms are *GST trade name* and *recipient details*. The provision of information rules in the Tax Administration Act 1994 will continue to apply to this information.

The primary list of required supply information continues to be:

- prescribed information identifying the supplier and the recipient
- the amount of the consideration payable for the supply of goods or services
- the date of the supply
- a description of the goods or services supplied
- the amount of GST charged for the supply (which can be on an inclusive basis).

For the following types of taxable supplies, again there is no change in the information requirements for either the supplier or recipient for:

---

<sup>7</sup> Part 4 of the Contract and Commercial Law Act 2017.

- a receipt provided by a supplier of distantly taxable goods
- information provided to the Customs Service by a supplier of distantly taxable goods
- supply information required for a buyer-created invoicing process (see below for proposed changes to this process)
- supply information required for receipts for taxable supplies having low-value consideration (this threshold is proposed to increase from \$50 to \$200). The \$200 value correlates to electronic “PayWave” transaction limits and was suggested by some submitters on the GST issues paper)
- tax invoices issued for supplies made before the application date of the proposed changes.

A minor change to current law for information requirements relates to the supplier’s obligation to provide supply information for a taxable supply to a registered recipient at the time of supply, only on request.

The proposed amendments would require the supplier to provide a registered recipient with the taxable supply information, which is consistent with commercial practice. The current law provides that a tax invoice must be provided only at the request of the recipient. The on-request approach is proposed to continue for any recipient of a supply of goods or services, to ensure that:

- a copy of the taxable supply information can be obtained by a registered recipient if the original taxable supply information has been lost or become corrupted, and
- an un-registered recipient who later becomes registered for GST, is able to ask for relevant supply information from the supplier (assuming that information remains available). This ensures that supply information can be available to the recipient to support input tax deductions for secondhand goods.

Consequential amendments are also proposed for a number of rules to update references to the terminology proposed for modernising record keeping requirements.

Rules relating to supply information for GST and supplier groups are also proposed to be amended to ensure consistency with these general changes. These proposed amendments are discussed later in a separate commentary item titled “GST Groups”.

### ***Correcting supply information***

Under current law, supply information in the tax invoice can be corrected if a taxable supply is:

- cancelled, or
- the supply information set out in a tax invoice is fundamentally different from the nature of the goods or services supplied, and
- in some other limited circumstances.

This correction process uses either a debit note (to increase the GST charged on the supply) or a credit note (to cancel or reduce the GST charged on the supply). Both a debit note and a credit note are currently defined to be:

- a document that is provided under the relevant provision of section 25; and includes

- a document deemed to be a credit note or a debit note under the relevant provision of section 25.

The amendments propose that a registered person may create supply correction information for:

- a cancellation of a taxable supply, or an increase or decrease in the GST amount previously recorded (no change), or
- to correct other incorrect supply information previously recorded, provided the correction is within the scope of Inland Revenue guidelines for making such corrections.

This list of information is proposed to be termed *supply correction information*. It is also proposed that it would no longer be necessary to have separate processes for credit or debit adjustments. The new process replaces the requirements relating to credit and debit notes.

The amendments also propose that a registered person creating supply correction information must provide that information to the other registered person who is a party to the supply, and all parties to the supply must retain this information in their business records required and retained by both the supplier and recipient (correction information). This is necessary to ensure that the recipient of a taxable supply has the correct available information when making an input tax deduction in their GST return.

It will continue to be possible to request a copy of supply correction information, but it would no longer be mandatory to include the words “copy only” on that copy (if that information remains available). This supports the obligation for the recipient of a supply to have supply information records that support all input tax claims.

In addition, an issue raised in submissions on the GST issues paper is that the current rules for debit notes and credit notes are not sufficiently flexible to allow supply information to be corrected. For example, spelling errors in the recipient’s name, or the description of the nature or quantity of the goods or services supplied. The proposed amendments would also allow such errors to be corrected. It is anticipated that the Commissioner will issue guidelines relating to the correction of errors under this proposed process.

### ***Copies of supply information***

If a copy of taxable supply information or supply correction information is requested, it would no longer be mandatory to require this information to be marked “copy only”. This proposal was supported by submissions on the GST issues paper.

An integrity risk may arise due to the copies not being marked “copy only”. This is addressed in the proposed amendments, which would:

- require the recipient of a taxable supply to have business records to support input tax deductions included in their GST return for a taxable period, and
- impose a strict liability penalty on the recipient if multiple input tax deductions are taken for the same taxable supply.

This strict liability penalty would replace the current knowledge offence for issuing more than one tax invoice for a single taxable supply (see later in this commentary for more information).

### ***Buyer-created taxable supply information***

Under current law, GST-registered buyers must obtain Inland Revenue's prior approval to issue buyer-created tax invoices. These invoices must contain the same supply information that is required for a taxable supply having a value greater than \$1,000. A buyer can be approved to issue invoices for:

- particular goods or services, or
- a particular supplier or group of suppliers.

A buyer-created tax invoice can only be used if both the buyer and the seller:

- are GST registered
- agree in writing that only the buyer will issue the tax invoice, and
- keep a copy of the tax invoice.

Submissions on the GST issues paper identified that this pre-approval process creates relatively high levels of compliance and administration costs.

The amendments propose to remove the requirement to have Commissioner pre-approval and instead require an agreement between the supplier and recipient (both must be registered persons) that is recorded by both parties. The agreement must record:

- that only the recipient will create the taxable supply information and that the recipient will provide that information to the supplier, and
- the reasons for entering into the agreement.

If the Commissioner considers the agreement is inconsistent with legislative parameters, the Commissioner may treat the agreement as invalid. This would result in the person not being able to continue to use this process.

### ***Shared tax invoices and supplier groups***

Under current law, a registered person may issue a tax invoice on behalf of multiple registered suppliers in situations where either:

- the suppliers are all part of a group of companies, or
- the suppliers have statutory obligations which make it practical to use a single invoice.

The proposed amendments would clarify that the shared invoice process will continue to apply to a group of registered persons provided they are also not part of a GST registered group.

The amendments also propose that registered persons using the shared invoice process would be required to document in an agreement setting out:

- the reasons for adopting the shared invoice process (these would be consistent with published guidelines for acceptable use of the shared invoice process)
- the joint and several liability for GST obligations for each taxable supply
- which registered person will create taxable supply information (no change), and
- certain identifying GST information for each party to the agreement (no change).

Consistent with submissions received on the GST issues paper, the registered person that is currently termed the principal supplier, is proposed to be an agent for each registered person that is a party to that agreement. This agency would only apply in relation to supplies to which the agreement applies.

If the Commissioner considers the agreement is inconsistent with the legislative parameters, the Commissioner may treat the agreement as invalid. This would result in the person not being able to continue to use this process.

### ***Recipient obligation to have business records that supports input tax deductions***

#### *Current information requirements*

To support the integrity of the GST system, current law in broad terms requires:

- a registered person making a taxable supply to issue a tax invoice and retain that document in their business records
- a registered supplier to provide the tax invoice to a registered recipient of the supply, but only on request
- a registered recipient making input tax deductions in a GST return, to have a tax invoice for input tax deductions claimed, if the consideration for the supply is more than \$50 (low-value threshold)
- in limited circumstances, if a tax invoice has not been provided to the recipient of the supply, the Commissioner may approve the use of business records to support an input tax deduction
- for secondhand goods input tax deductions a minimum set of information requirements must be satisfied, and
- for taxable supplies having a consideration under the low-value threshold, the registered recipient is expected to a business record to evidence the input tax deduction (usually a till receipt).

Some of these rules bear a relatively high compliance and administration cost because they require interaction with the Commissioner to determine whether it impractical to issue the records that contain the necessary evidence to support the input tax deduction.

#### *Proposed supply information requirements*

The GST issues paper proposed that rather than relying on a formal “tax invoice”, a wider set of ordinary business-to-business information, including electronic information, could be able to be used to support GST output tax and input tax.

The proposed amendments in this Bill reflect the policy proposal in the GST issues paper. The proposed amendments also clarify that the supplier must provide the relevant supply information at the time of supply unless the recipient is not a registered person. The form of provision of that information is to be determined by the supplier. An unregistered recipient of a taxable supply may request to receive the relevant supply information at the time of supply or at a later time.

### *Proposed changes for information required to support an input tax deduction*

The proposed amendments would clarify that an input tax deduction must be supported by the registered person's business records which show that the person:

- has borne GST on those supplies, or
- meets the information requirements for secondhand goods.

Typically, contractual arrangements and associated recordkeeping required under commercial law will result in transactional information being created and retained in business records that is consistent with the information requirements of the GST system.

As an input tax deduction is proposed to be supported by the registered person's business records, it would be no longer necessary to have the current provision that requires Commissioner involvement in relation to recordkeeping.

Consequentially, the proposed amendments would require a registered supplier to provide supply information to the recipient of the supply at the time of supply, unless the recipient is not a registered person. This differs from the current law which requires this information to be provided only on request. In practice, we observe that many suppliers already follow this process.

This proposal may result in some minor change in business processes at point of sale for some small and medium size business sectors, mainly relating to determining if the recipient requires the supply information. Under this process, it would be sufficient for the supplier to determine if the recipient requires the supply information. If a recipient is a registered person, the recipient should always require the supply information as this is essential information to support the input tax credit process.

Submissions on the GST issues paper were supportive of business records being used to support input tax deductions rather than requiring a formal document, such as a tax invoice.

This proposal will be supported by a proposal to impose a strict liability penalty for claiming input tax more than once for the same taxable supply (see below).

#### ***Strict liability penalty***

Submissions to the GST issues paper considered that criminal offence potentially applied to the wrong registered person, as multiple tax invoices for a single taxable supply were either a mistake or could be the result of taking an abusive tax position, evasion or fraud (each of which would have their own consequences).

Under current law, a supplier of goods and services issuing multiple tax invoices for the same supply commits a criminal offence (termed a knowledge offence). Conviction for a knowledge offence exposes the supplier to a sanction of imprisonment not exceeding five years, a fine not exceeding \$50,000, or both imprisonment and a fine, for each offence.

The amendments propose to repeal the knowledge offence penalty for issuing multiple tax invoices for a single taxable supply and replace it with strict liability offence which carries a lower level of sanctions.

The replacement strict liability offence (also a criminal offence) would apply to a registered person who claims an input tax credit more than once for the same taxable supply. This is consistent with submissions made on the GST issues paper.

This new penalty would only apply if the registered person has not taken reasonable care in ensuring they have not made more than one input tax deduction for the same taxable supply, or that person has already self-corrected for a multiple input tax deduction claim in a subsequent GST return. The sanction for the proposed strict liability offence provides for a scale of fines (a maximum of \$12,000), depending on how many times the person is convicted under this rule. Existing guidelines would apply for determining when reasonable care has been taken.

## **SECONDHAND GOODS INPUT TAX CREDIT – ASSOCIATED PERSONS SUPPLIES**

---

*(Clause 6)*

### **Summary of proposed amendment**

The proposed amendments would allow an input tax credit for a supply of secondhand goods from an associated person by reference to the last known supply from a non-associated person. The proposed amendment would not apply to a supply of goods that were acquired by the supplier before GST was introduced.

### **Application date**

The proposed amendment would apply for taxable periods starting on or after the date of enactment.

### **Key features**

The current rule prevents a registered person from having an input tax credit for secondhand goods acquired from an associated person who had not previously acquired those goods as a taxable supply.

The proposed amendment would allow an input tax credit for secondhand goods acquired from an associated person as follows:

- if the associated supplier has purchased the secondhand goods from a non-associated person, an input tax deduction allowed would be equal to the tax fraction of that earlier purchase price from the non-associated person, or
- if the associated supplier has purchased the second-hand goods from an associated person, an input tax deduction would be allowed only if an earlier supply with a non-associated person can be identified after 1 October 1986. In this situation, the input tax deduction allowed would be equal to the tax fraction of that earlier purchase price from the non-associated person.

### **Background**

The input tax deduction for a supply of secondhand goods to an associated person is intended to have the same outcome for input tax that would be allowed if the supplier had, instead of making an associated person transaction, started using the secondhand goods in their own taxable activity. In this situation, the owner of the secondhand goods would receive an input tax deduction that takes into account previous GST costs embedded in the purchase price of the owner of those goods.

The GST issues paper proposed amending the law to allow an input tax credit if a registered person is denied a secondhand goods input tax credit, where previous GST costs have been embedded in the transactional cost of the asset.



Example 21 illustrates the policy problem and the outcome that would be achieved by the proposed amendments.

**Example 21: A developer sells a property to Sam for \$1.15 million, including \$150,000 of GST**

Sam is not registered for GST (or, if registered does not use the property to make taxable supplies). Two months later Sam sells the property for \$1.2 million to John. As this sale is not subject to GST, there is no GST included in the sale price to John.

John lives in the property for five years and then sells the property for \$1.5 million to his sister, Jasmine who will re-develop the property to use it as the premises for her business of making taxable supplies.

Current law would limit the secondhand goods input tax credit to the GST included in the original cost to John, which was zero – therefore Jasmine is unable to claim any secondhand goods input tax credit. This is despite GST of \$150,000 being embedded in the chain of transaction costs.

The intended result is that Jasmine should be able to claim a secondhand goods input credit based on the tax fraction (3/23rds) of the original cost to John which would be a \$150,000 secondhand goods input credit.

The policy objective is for the input tax deduction rule to give the same input tax deduction (in total) overall that John would have if, instead of selling the secondhand goods to Jasmine had applied the goods 100% in a taxable activity.

Under the current adjustment rules, if the property was applied 100% to a taxable activity of John, the total amount of input tax deduction allowed to John would be equal to the tax fraction of the cost of the property purchased from Sam. The proposed amendments achieve this outcome and also ensure that a chain of associated person supply transactions is looked through to determine the first non-associated supply introduced to that chain

In addition, the current rule for supplies of secondhand goods between associated persons prevented an input tax deduction for secondhand goods acquired before the commencement of GST. This was achieved in the current rule for acquisitions of secondhand goods from an associated person by the limitation on the input tax credit for the amount of tax included in the original cost of the goods to the supplier.

The proposed amendment bases the amount of the input tax deduction on the tax fraction of the purchase price. Therefore, it is necessary to ensure that an input tax deduction for secondhand goods cannot arise if the relevant supply of secondhand goods was from goods acquired by the supplier before GST commenced in 1986. This is proposed to be set out in the requirements that must be satisfied for a person to have an input tax credit for secondhand goods.

This proposed amendment ensures that a secondhand goods input tax credit cannot arise if either:

- the supplier acquired the goods before 1 October 1986, or
- the supplier acquired the goods as part of a chain of transactions between associated persons dating back to before 1 October 1986.

## **GST INPUT TAX RECOVERY FOR NON-RESIDENT BUSINESS**

---

*(Clause 21(8))*

### **Summary of proposed amendment**

The proposed amendment would allow a GST registered non-resident business to claim input tax deductions for all their GST costs purchased in New Zealand that are used to make supplies outside New Zealand.

Some consequential amendments are also proposed which would prevent a GST registered non-resident business from claiming a GST input tax deduction for any GST paid to Customs on imported goods that are supplied to a final consumer in New Zealand.

### **Application date**

The proposed amendments would apply from the date of enactment.

### **Key features**

A proposed amendment would expand section 20(3L) so that it applies to all GST registered non-residents. These GST registered non-residents would then be able to deduct input tax for goods and services purchased by them that are used for, or available for use in, making taxable supplies, treating all supplies made by them as if they were made and received in New Zealand.

Proposed new section 20(3LB) would allow a similar input tax deduction for when the GST registered non-resident has imported goods and paid GST to Customs on the imported goods unless new section 20(3LC) applies.

Proposed new section 20(3LC) would exclude an input tax deduction for the Customs GST paid on imported goods if those goods are supplied to another person in New Zealand who is not a GST registered person, or, who is a GST registered person and the supply is not for use in their taxable activity. This means no input tax deduction can be claimed by the non-resident in respect of any imported goods that are supplied to a final New Zealand consumer.

### **Background**

A GST registered non-resident business may send their goods to New Zealand for work to be done on them by a New Zealand resident business. Once work is complete, the non-resident will often export some of the goods outside of New Zealand. Unless they establish a fixed or permanent place in New Zealand, the non-resident is currently unable to claim input tax deductions for their New Zealand inputs that relate to the exported goods. This is because section 8(2) deems the supply of these goods to occur outside New Zealand.

The proposed amendments would allow the GST registered non-resident business to claim input tax deductions for their New Zealand inputs that relate to the exported goods. This would reduce the compliance costs associated with establishing a fixed or permanent place in New Zealand and ensure that GST is not a cost borne by businesses.

The proposed amendments achieve this by expanding the scope of an existing input tax deduction rule in section 20(3L) which allows deductions for certain non-resident businesses, so it would apply to all GST registered non-residents.

Existing rules in section 20(3LB) and 20(3LC) prevent an input tax deduction from being claimed by a non-resident if they pay Customs GST and deliver goods to a final consumer in New Zealand. The current rules achieve this by deeming the Customs GST to be paid by the New Zealand person who receives the goods, rather than the non-resident importer.

However, the current deeming rule means that when the GST registered non-resident pays Customs GST on behalf of a GST registered New Zealand business, the New Zealand business needs to claim an input tax deduction for this Customs GST and reimburse the non-resident. This process can be confusing for the parties involved and lead to errors or higher compliance costs.

Therefore, the proposed amendment would replace the deeming rule in sections 20(3LB) and 20(3LC) with a proposed new section 20(3LC). This would prevent an input tax deduction from being claimed by the non-resident in respect of Customs GST paid on any imported goods that are delivered to a person in New Zealand who is not a GST registered person, or, who is a GST registered person and the supply is not for use in their taxable activity. The input tax deduction for Customs GST is denied where the imported goods are outside New Zealand at the time of supply.

## **EXPORTS OF GOODS THAT ARE DELIVERED TO A RECIPIENT'S VESSEL IN NEW ZEALAND**

---

*(Clause 10)*

### **Summary of proposed amendment**

The proposed amendment would allow a supplier to zero-rate a supply of goods to a recipient who then exports those unaltered goods from New Zealand.

### **Application date**

The proposed amendment would apply from the date of enactment.

### **Key features**

Section 11(1)(eb) of the Goods and Services Tax Act 1985 allows a supplier who delivers goods to a non-resident recipient who then exports those goods outside of New Zealand to zero-rate the supply. However, section 11(1)(eb) does not apply if the recipient is a resident.

The proposed amendment would allow a supplier to zero-rate the supply of goods to a resident recipient for export. This would be achieved by expanding section 11(1)(eb)(i) so that it is not limited to cases where the recipient exporter is a non-resident. The other conditions of section 11(1)(eb)(ii)–(vi) would remain in place and must be met for the supply of goods to the recipient to be zero-rated. For example, a supplier who delivers logs to the ship of a recipient who then exports the logs outside of New Zealand would be able to zero-rate the supply of logs.

The proposed amendment would reduce compliance costs for the supplier and the recipient.

## **GROUND LEASES PAID VIA A UNIT TITLE BODY CORPORATE**

---

*(Clause 7(3))*

### **Summary of proposed amendment**

The proposed amendment would deem a GST registered unit title body corporate to not be making taxable supplies to its members for any portion of a levy charged by the body corporate for supplies which would be exempt supplies if they were provided directly to the member.

### **Application date**

The proposed amendment would apply from the date of enactment.

### **Key features**

When a GST registered unit title body corporate charges a levy to its members, section 5(8A) deems there to be a taxable supply of services to the members. This means that a GST registered unit title body corporate must charge and remit output tax on the levy to Inland Revenue. Section 5(8A) deems there to be a taxable supply in relation to the whole of the levy or other amount paid, even though a portion of that levy may be used to purchase exempt supplies such as a lease on leasehold land to the extent that land is used for the principal purpose of accommodation in a dwelling erected on that land.

The proposed amendment would qualify section 5(8A) so that the portion of a unit title body corporate levy that relates to the purchase of exempt supplies is not treated as consideration for services supplied to the member. This means that GST would not be charged on the portion of the levy that represents payment for exempt supplies (as defined in section 14). For example, where a unit title body corporate charges to its members a levy of \$500, and \$300 of that levy is paid to the leasehold landowner for ground rent on land that is used for the principal purpose of accommodation in a dwelling erected on that land, the body corporate would only be making a taxable supply in relation to the \$200 that does not represent consideration for the exempt supply.

## **GST B2B COMPULSORY ZERO-RATING OF LAND RULES**

---

*(Clauses 7(5), and 33(1), 33(3) and 33(4))*

### **Summary of proposed amendments**

Three proposed remedial amendments would amend the GST business-to-business compulsory zero-rating of land rules. The proposed amendments would apply in cases where a registered person has incorrectly zero-rated a supply of land and is required to make subsequent adjustments.

Two of the proposed remedials would clarify that the adjustment should be made in the period that the error became apparent, rather than the period when the original supply took place.

The third proposed remedial would allow a non-taxable supply that has been incorrectly zero-rated to be correctly adjusted to be a non-taxable supply.

### **Application date**

The proposed amendment to the timing of an adjustment under section 25AB of the Goods and Services Tax Act 1985 (GST Act) would apply for taxable periods starting on or after the date of enactment.

The proposed amendments to the timing and nature of the adjustment under section 5(23) of the GST Act would apply from the date of enactment.

### **Key features**

#### ***Timing of an adjustment under section 25AB***

A registered person may claim a secondhand goods input tax deduction when they purchase land from a non-associated person who has not made a taxable supply. If, subsequent to the supply of land, it is found that the supply should have been zero-rated under section 11(1)(mb), the recipient of the supply is required to make an output tax adjustment for the underpaid GST in the taxable period in which the “event” occurred under section 25AB. In this case, the “event” is the incorrect treatment of the supply of land as a non-taxable supply for which the recipient claimed a secondhand goods input tax deduction. The output tax is therefore owing in the taxable period in which the land was supplied. This means the recipient will be liable to pay penalties and use of money interest, and there is a risk that the necessary adjustment may have since become time barred.

The proposed amendment would address these concerns by ensuring that the liability to pay output tax only arises on the date it is found that the amount of input tax deducted by the recipient was incorrect. This is achieved by amending section 25AB so that it refers to the time the error was discovered when determining the adjusted tax liability of the recipient of the supply.

### ***Timing of an adjustment under section 5(23)***

A registered person must zero-rate a supply of land to another registered person when the requirements under section 11(1)(mb) are met. If, subsequent to the supply of land, it is found that the supply did not meet the requirements for zero-rating under section 11(1)(mb), the recipient of the supply is required to return output tax on the purchase price. This output tax liability is attributed to the taxable period in which the date of settlement occurred. This means the recipient will be liable to pay penalties and use of money interest, and there is a risk that the necessary adjustment may have since become time barred.

The proposed amendment would address these concerns by ensuring that the liability to pay output tax only arises in the taxable period where the recipient becomes aware that the zero-rating rules did not apply to the original supply. This is achieved by amending section 5(23) so that the supply of land by the recipient is deemed to occur on the date on which the error in application of the zero-rating rules is discovered. This means that the recipient's output tax liability would occur in the same taxable period that they would be entitled to claim an input tax deduction (to the extent to which they are using the land to make taxable supplies).

### ***Nature of the adjustment under section 5(23)***

A supplier must zero-rate a supply of land to a recipient when the requirements of section 11(1)(mb) are met. If, subsequent to the supply of land, it is found that the supply was incorrectly zero-rated and should have instead been treated as a non-taxable supply for which the recipient could claim a secondhand goods input tax deduction, the recipient is currently unable to claim this deduction.

The proposed amendment would allow the recipient to claim a secondhand goods input tax deduction where they meet the requirements of section 3A(2). This would be achieved by limiting the application of section 5(23), so that it would only apply where there has been a taxable supply of goods.

## **GST – DEDUCTION NOTICES FOR MEMBERS OF UNINCORPORATED BODIES AND PERSONS WHO ARE NO LONGER REGISTERED**

---

*(Clause 35)*

### **Summary of proposed amendment**

The proposed amendments would ensure that deduction notices could be used to recover outstanding GST debt from members of unincorporated bodies, and from persons who are no longer registered for GST.

### **Application date**

The proposed amendments would apply from the date of enactment.

### **Key features**

The proposed amendments are designed to:

- resolve a technical issue with the Goods and Services Tax Act 1985 (GST Act) that prevents the Commissioner from being able to recover outstanding GST debts from members of unincorporated bodies, despite them being jointly and severally liable for the obligations of the unincorporated body, and
- ensure that the Commissioner can still recover outstanding GST debts by way of a deduction notice, whether the person who incurred the debt is registered for GST or not.

### **Background**

The Commissioner has the power under various Inland Revenue Acts to issue deduction notices as a means of collecting outstanding tax debts. The GST Act permits the Commissioner to issue deduction notices, which require a person (usually an employer or a bank) who owes an amount to a debtor to extract and pay to the Commissioner from that amount an amount in satisfaction of the debtor's tax debt. In this regard, deduction notices are an effective and an efficient means of collecting outstanding tax debts.

For GST, the Commissioner can issue deduction notices that have effect in respect of outstanding GST owed by a registered person. This means that deduction notices cannot be used to recover outstanding GST from members of unincorporated bodies (such as partners in partnerships, and trustees of trusts) because the members themselves are not regarded under the GST Act as registered persons, and instead the GST Act treats the unincorporated body itself as the registered person. This also means that deduction notices cannot be used to recover outstanding GST that relates to a person who is no longer a registered person under the GST Act. Neither of these outcomes are intended, and it is noted that the Commissioner is not prevented from recovering outstanding tax debts in these circumstances for other tax types such as income tax and PAYE.



## Detailed analysis

The proposed amendment inserts new subsection (2AA) to section 43 (Deduction of tax from payment due to defaulters) which would make it clear that the Commissioner can issue deduction notices to recover outstanding GST from both registered persons themselves (such as the case now), and persons liable to meet the obligations under the GST Act of a registered person (defined in the amendment as a “liable person”). A person is a liable person if they are liable to meet the obligations under the GST Act of a registered person. This would be the case where:

- The person was a member of an unincorporated body that itself was registered for GST. This is because the members of unincorporated bodies are jointly and severally liable for the tax payable by the unincorporated body, whether still a member or not.
- The person is no longer registered for GST (and is therefore not a registered person) but nevertheless continues to be liable for the obligations and liabilities incurred by the registered person while they were registered. This would also include members of unincorporated bodies, where that unincorporated body ceased being a registered person.

Further consequential amendments are proposed to section 43 of the GST Act to allow the Commissioner to recover outstanding GST debts from members of unincorporated bodies, and from persons who are no longer registered persons under the Act. These proposed amendments involve adding references to “the registered person or the liable person” to provisions which currently only apply to the registered person.

## **GST GROUPS**

---

*(Clauses 9, 36, and 37)*

### **Summary of proposed amendment**

The proposed amendments to the GST group rules would mainly resolve an identified ambiguity in the current law relating to the relationship of the GST group provision with the other rules underpinning the GST system. This ambiguity was identified in an issues paper released in February 2019 by Inland Revenue's Public Rulings Unit on the consequences of GST group registration (IRUIPP 13).

The proposed amendments clarify that the GST group rules would:

- apply as if the group were a single registered person for all activities carried on by any member within the group for supplies made to third parties
- disregard most intra-group supplies in determining the group's GST liability for each taxable period
- clarify which intra-group supplies are included in the group's GST return
- apply joint and several liability on the same basis as for consolidated groups in the Income Tax Act 2007
- allow a group to nominate a member company to create and issue all supply information records for taxable supplies, and
- be consistent with the proposed amendments to modernise information requirements for the GST system.

### **Application date**

The proposed amendments would apply for taxable periods beginning on or after the date of enactment.

### **Key features**

The proposed amendments for GST groups would:

- address an ambiguity in the law about the relationship of the grouping rules to the other rules in the Goods and Services Tax Act 1985
- simplify compliance requirements by allowing the group to choose a group member company to comply with the modernised information requirements
- clarify that the representative member is responsible for making elections and giving notices on behalf of the group, in particular for elections and notices relating the activities of the GST group
- update some rules for groups to be consistent with the modernisation of invoicing proposals also included in this bill. These proposals have resulted in renumbering of existing rules, and

- provide a framework for identifying any intra-group supply transaction that must be included in the group GST return for the relevant taxable period.

The ambiguity identified is proposed to be addressed by clarifying that supplies made by any member of the group to third parties that would be a supply by that member in the absence of the GST group rules are treated for GST purposes as made by the representative member of the group

Clause 9 provides a signpost for readers to indicate the GST group rules are to be read in conjunction with the core rules in Part 2.

Clause 36 proposes consequential terminology updates relating to the term GST group and the modernisation of invoicing.

## **Detailed analysis**

### ***Treatment as a single company***

The proposed amendments would result in a GST group being mostly treated, for GST purposes, as a single company that:

- operates each business carried on by any member of the group (a clarification)
- makes and receives each supply to a person that is not a member of the group, this includes exempt supplies (a clarification)
- treats the representative member as the person acting on behalf of the group for elections, giving notices, keeping records, and accounting for GST for the group (no change)
- permits a GST group to choose to issue taxable supply records for taxable supplies to third parties in the name of either the representative member or a member company (allows GST groups more flexibility in their GST systems)
- the representative member and members of the group are to share the responsibilities and liabilities arising from the members' business activity, and
- is not required to account for GST in a GST return for taxable supplies made between members of the group, unless specifically required to account for those intragroup supplies.

Clause 9 proposes a signpost to the special case rules in Part 9, which includes the GST group rules. This proposed amendment provides a signal for the reader that the rules in section 55 are intended to be applied first when determining how GST is accounted for by the representative member of a GST group.

### ***Representative member treated as carrying on all activities***

The proposed amendments clarify that the representative member carries on all taxable activities and exempt activities that are carried on by any member of the group where those supplies would otherwise be taxable to the member.

Each of those activities would be treated in the same manner as if they were carried on by a branch within a single company that is registered for all of its taxable activities. This would

ensure that the multiple activities are not treated as being merged into a single taxable activity, and that the individual activities would retain their unique nature.

The representative member is to continue to be responsible for:

- filing GST returns for the group, and
- satisfying GST payment obligations for the group.

The proposed amendments would also ensure that apportionments and adjustments would be calculated by reference to the total activities carried on within the group, including exempt activities. These proposals would improve the integrity of the GST system for GST groups. The representative member would continue to be treated as:

- making all taxable and non-taxable supplies made by any group member to a third party, and
- receiving all taxable and non-taxable supplies made to any group member by a third party.

Intra-group supplies would continue to be disregarded, unless specifically identified to be included in the GST group's return for a taxable period.

### ***Intra-group supplies***

A new provision provides a framework for listing types of intra-group supplies that must be taken account of in a group GST return. For example, if a provision is not listed in this proposed section, taxable supplies made in New Zealand between members of the GST group are disregarded in the preparation of the group GST return for each taxable period.

### ***Information requirements***

Under current settings, each member of the GST group is required to issue tax invoices and keep records for all taxable supplies.

As a simplification measure, it is proposed that a group may choose that supply information for these supplies to be issued and retained by either:

- the representative member, or
- a nominated company (for example, an administration company that maintains all record keeping functions for the group), or
- the supplying member itself.

The form of creating and retaining and issuing that information would be determined by the group. However, if the group chooses to have an administration company maintain all record-keeping functions for the group, the amendments propose that the identity of this company and its role are notified to the Commissioner of Inland Revenue.

However, irrespective of which company issues and retains information for taxable supplies and any related subsequent adjustments, this company would need to meet the minimum information requirements set out in the rules proposed for modernising GST recordkeeping processes. The representative member is to remain responsible for ensuring that the record-keeping processes are complied with.

### ***Eligibility to be in a GST group***

The eligibility rules for being included in a GST group remain unchanged, although the drafting is updated for consistency with other amendments for GST groups.

### ***Joint and several liability***

The proposed amendments would align the joint and several liability provisions with the joint and several liability provisions for consolidated groups of companies in the Income Tax Act 2007. Joint and several liability generally will continue for GST obligations incurred while a member of the group.

The Commissioner may choose to grant relief under the proposed amendments, if all of the following are satisfied:

- the assessment is a reassessment made after the later of the date the exiting company leaves the GST group, and the date of the event that results in that member being treated as having left the group
- the amount assessed is an increased assessment, and
- the Commissioner considers the removal of joint and several liability will not significantly prejudice the recovery of the increased assessment and has notified the member and the GST group of this conclusion.

### ***Commencement of membership of a GST group***

The proposed amendments would clarify the start date for a member company that is newly incorporated. The representative member may choose that the start date of membership is either:

- the date of the company's incorporation, or
- the start of the taxable period following the date of incorporation.

## **NON-STATUTORY BOARDS**

---

*(Clause 8)*

### **Summary of proposed amendment**

The proposed amendment would remove the word “statutory” from this provision. This would ensure that all boards are treated the same for GST purposes.

### **Application date**

The proposed amendment would apply from the date of enactment.

### **Key features**

The proposed amendment would ensure that when a natural person who is a registered person, provides services to local authorities, boards, committees, any other council, they are treated the same for GST purposes. This would also ensure that the bodies on which they serve are also treated in the same way for GST purposes for those services, irrespective of their statutory or non-statutory status.

### **Background**

The proposed amendment stems from a proposal set out in the February 2020 GST issues paper. The issues paper identified that the wording of the law is inconsistent with the policy intent. In particular, the application of the law was resulting in a different GST treatment as between services supplied:

- by members of statutory bodies, such as a local authority (the service is not subject to GST), and
- by members of non-statutory bodies, such as community boards (the service is potentially subject to GST).

## **MORE FLEXIBILITY FOR CHANGING END DATE FOR TAXABLE PERIOD**

---

*(Clauses 9, and 13–18)*

### **Summary of proposed amendment**

The proposed amendments would allow the Commissioner to approve a registered person to use their accounting cycle as the basis for calculating GST payable for a taxable period. The Commissioner would need to be satisfied that the request to change their end date of a taxable periods is consistent with the purpose of aligning the person's accounting system.

Under the proposed amendments, the end date of the accounting cycle would be aligned with the last day of a month using late and early balance date principles similar to those used in the Income Tax Act 2007 for non-standard balance dates.

### **Application date**

The proposed amendments would apply for taxable periods starting on or after the date of enactment.

### **Key features**

A registered person may apply to Inland Revenue for approval to change the end date of a taxable period that is not within seven days of the end of a calendar month. The approved end date may be either a day of the week or a calendar date.

The change in the end date may be approved if the change would significantly improve the alignment of the registered person's taxable periods with their accounting systems.

If the request is approved, the end date of the registered person's accounting cycle would be treated for GST purposes as corresponding to:

- the end of the preceding month, if the end of the end date of the accounting cycle is on or before the fifteenth of the month, or
- the end of the current month, if the end date of the accounting cycle is after the 15th of the month.

The proposed amendments would:

- have an effect that is similar to the way in which late and early balance dates correspond to a tax year for income tax purposes, and
- provide for consistency with provisional tax methods, and due dates for satisfying GST obligations.

Clause 9 provides a signpost to the proposed amendments to the taxable period rules.

## Background

The proposed amendment stems from proposals in the February 2020 GST issues paper about the use of accounting systems of registered persons that do not coincide with the last day of the month. The issues paper noted that:

- the last day of the month is the normal end date for a taxable period
- an exception to this requirement exists, but is limited to an approved end date that is within seven days of the end of the month, and
- this requirement can require a relatively high level of compliance and administration cost if GST accounting cycles are not consistent with accounting cycles.

The issues paper also noted that for the concerns mainly relate to organisations using accounting cycles based on a “4 week – 4 week - 5 week” accounting system. Accounting for GST on the statutory cycle (to the last day of a month).

## Detailed analysis

### *Approvals*

A request for approval for an end date for a taxable period on the basis of aligning GST taxable periods with the registered person’s accounting cycles is proposed to be made under existing section 15(2). Inland Revenue’s GST guide<sup>8</sup> sets out that an application for changes to filing requirements is made in writing. This can include an application made in the registered person’s MyIR account.

The approved end date can be based on the end of an accounting cycle, which can be a specific day of the week (the dates will therefore vary) or can be based on a fixed calendar date.

The proposed amendments would take effect from the end of the taxable period in which the person applies or at the end of a later taxable period nominated by the registered person.

The proposals would also allow an application for approval to be for the accounting cycle that would be equivalent to either a 1-month or 2-month or 6-month taxable period

### *Alignment of approved taxable period with end of the month*

If Inland Revenue approves the end date of a taxable period to be other than the end of the month, the end date of the registered person’s accounting cycle is treated for GST purposes as corresponding to:

- the last day of the month, if the accounting cycle ends on or after the 16th of the month (for example, 16th March is treated as taxable period ending on following 31 March – late end date), or
- the last day of the previous month if the accounting cycle ends on or before the 15th of the month (for example, 13 April is treated as taxable period ending on prior 31 March).

---

<sup>8</sup> Inland Revenue. (March 2021). *GST guide – working with GST* (IR375). <https://www.ird.govt.nz/-/media/project/ir/home/documents/forms-and-guides/ir300---ir399/ir375/ir375-2021.pdf>



As it is possible for the end date of successive accounting cycles to vary (where the accounting cycles end on a particular week day), this could result in those end dates of the accounting cycles corresponding to the same end date of a month. Consequently, the proposals would permit the GST information from those two accounting cycles to be aggregated and returned as one taxable period.

Example 22 illustrates this outcome.

**Example 22**

Under the 4-4-5 cycle ending on a Thursday (for a monthly GST cycle), allowing the cycle to be based on a fixed day of the week, can result in an early and late balance date falling into the same taxable period. If two approved end dates relate to the same end of month date, then the second of those two dates is ignored – and the two four weekly cycles are combined as one taxable period so that GST returns for all taxable periods include the information for all taxable supplies and input tax deductions.

Month 1	18 Nov 2021	Early bal date for 30 Nov
Month 2	16 Dec 2021	Early bal date for 31 Dec [combine accounting cycles for the 31 Dec GST return]
Month 3	13 Jan 2022	Late bal date for 31 Dec [combine accounting cycles for the 31 Dec GST return]
Month 4	10 Feb 2022	Late bal date for 31 Jan
Month 5	10 Mar 2022	Late bal date for 28 Feb

## **TAXABLE SUPPLIES OF GOODS NOT YET IN PHYSICAL POSSESSION**

---

*(Clause 21(4))*

### **Summary of proposed amendment**

The proposed amendments would allow an input tax deduction for goods acquired but not yet physically received if they are expected to be used in making taxable supplies and have not been acquired from an associated person. This would correct an inadvertent change made on 1 April 2011 that resulted in a narrowing of allowable input tax deductions for goods acquired by a registered person but which remained in transit at the time of preparing the GST return.

### **Application date**

The proposed amendment would apply to supplies of goods made on or after 1 April 2011.

### **Key features**

The proposed amendments would allow an input tax deduction for goods acquired but not yet physically received if:

- the goods are expected to be used in making taxable supplies, and
- the goods have not been acquired from an associated person.

The limitation on the proposed amendment for associated person transactions addresses an integrity risk for the GST system to prevent asymmetrical transactions to give beneficial GST outcomes for the associated persons.

## **CHALLENGE RIGHTS – ASSESSING TIME-BARRED GST RETURNS**

---

*(Clause 155)*

### **Summary of proposed amendment**

The proposed amendments would provide that a Commissioner assessment for a time-barred GST return is treated as a disputable decision.

### **Application date**

The proposed amendment would apply for taxable periods starting on or after the date of enactment.

### **Key features**

The proposed amendments would provide that a Commissioner's decision to reopen an assessment for a time barred GST return is treated as a disputable decision. Under current law, such a Commissioner assessment could only be challenged under a judicial review process.

The proposed amendment would align the treatment of Commissioner assessments for time barred periods as between income tax and GST.

## REMEDIAL AMENDMENTS TO THE GST APPORTIONMENT RULES

---

### Background

The apportionment and adjustment rules apply when a GST-registered person uses or intends to use goods and services for both taxable and non-taxable purposes. Following acquisition of an asset, the GST-registered person must annually compare the intended taxable use of an asset with the actual taxable use of that asset. If there is a difference the person must make an adjustment to either claim extra input tax credits or pay output tax to reflect the actual taxable use of the asset.

Proposed remedial changes to the GST apportionment rules would increase the accuracy and fairness of the rules.

These proposed changes are discussed separately:

- zero-rated supplies of going concerns, and
- switching off adjustment provisions after a wash-up is performed.

## ZERO-RATED SUPPLIES OF GOING CONCERNS

---

*(Clauses 21(7) and 21(8))*

### Summary of proposed amendment

The proposed amendment introduces a provision that would require a purchaser who acquires goods which were zero-rated as the sale of a going concern and then uses those goods for a partly non-taxable use, to determine the amount of GST that would have been payable if the transaction was not zero-rated and apportion the amount accordingly.

### Application date

The proposed amendment would apply from the date of enactment.

### Detailed analysis

Under current section 11(1)(m) of the Goods and Services Tax Act 1985, the sale of a going concern between registered persons may be zero-rated if the supplier and recipient agree. The problem under current law is that if the purchaser utilises this going concern for a partly private use, there is no provision that requires them to determine the amount of GST that would have been payable if the transaction was not zero-rated and apportion the amount accordingly.

Clause 21(7) proposes an expansion to the scope of section 20(3J) so that this section would also apply to goods which were zero-rated as a going concern under section 11(1)(m) at the time they were acquired by the registered person. The proposed amendment would require the registered person to determine if they have any non-taxable use of the goods (such as private use or use of the goods to make exempt supplies) and return output tax in respect of 15% of the consideration they paid to acquire the goods multiplied by their percentage of non-taxable use.

This would ensure consistency with the zero-rating of land rules, which do require the purchaser to determine the nominal amount of GST that would have applied if the supply was standard rated and return output tax on the apportioned amount.

#### **Example 23: Kelvin**

Kelvin has a business selling ice cream. He enters into an agreement to sell the entire business, which includes an ice cream truck, to Stewart for \$100,000 (plus GST if any). This \$100,000 is made up of \$50,000 for the truck and \$50,000 for other assets. Kelvin and Stewart agree to zero-rate the sale of the business as a going concern. Stewart estimates that the private use of the truck will be 20%. Under current law, as no GST has been paid, Stewart does not need to account for this private use.

#### ***Under the proposed amendment***

Even though Stewart acquired the truck as a zero-rated supply, under the proposed amendment Stewart must first determine the amount of GST that would have been charged if the supply of the truck was not zero-rated. \$7,500 would have been charged on the \$50,000 truck had it not been zero-rated.

Stewart must then determine his non-taxable use of the truck, which he estimates to be 20% and return output tax on 20% of \$7,500, which equals \$1,500, in his next GST return.

## SWITCHING OFF ADJUSTMENT PROVISIONS AFTER A WASH-UP IS PERFORMED

---

*(Clause 23(1))*

### Summary of proposed amendment

Proposed section 21(2)(ac) of the Goods and Services Tax Act 1985 (GST Act) would provide a person with an exemption from making an adjustment for apportioned supplies if they have performed a “wash up” calculation under section 21FB of the GST Act. The wash up calculation under section 21FB applies when there has been a change to 100% taxable or 100% non-taxable use of an asset for two adjustment periods.

### Application date

The proposed amendment would apply from the date of enactment.

### Detailed analysis

The proposed amendment would ensure that a registered person is not required to continue to perform annual adjustments for goods and services that have had a complete change of use and have been subject to a wash-up under section 21FB. This would reduce unnecessary compliance costs for a taxpayer.

#### **Example 24: Ben**

Ben works part time running a flooring business. On 1 April 2021 he purchased a van for \$57,500. As the business is only part time, Ben’s uses the van for 50% taxable use, and fifty percent for private use. Ben claims an input tax credit of \$3,750 to account for the taxable use of the van.

On 1 April 2023 Ben switches the van to one hundred percent taxable use. This is because business has now picked up and Ben needs to work full time. He has also purchased another car for his private use.

On 1 April 2025, there has been two adjustment periods with 100% taxable use, so Ben performs a wash-up calculation under section 21FB and is able to claim an additional input tax credit. Ben’s total input tax deductions for the van will now add to \$7,500 or 100% of the GST component of the van.

The proposed amendment clarifies that Ben will not need to continue to perform annual adjustments for his van, as it has had a complete change of use and is 100% taxable.

This applies for as long as Ben’s use of the van remains 100% taxable. If, for example, Ben’s taxable use of the van changed on 1 April 2026 to 80% taxable and 20% private use he would need to make an adjustment to account for this.

The proposed amendment would apply provided that the registered person has not changed the use of the goods or services since performing the wash-up. If in a subsequent adjustment period the use of the asset changes, the registered person would be required to recommence calculating annual adjustments under the apportionment rules, unless one of the other section 21(2) thresholds is applied.

## **REPEAL REDUNDANT PROVISION**

---

*(Clause 45)*

### **Summary of proposed amendment**

The proposed amendment would repeal the transitional provision that applied to the vesting of railway assets in KiwiRail Holdings Limited in 2012 as this rule has served its purpose and is now redundant.

### **Application date**

The proposed amendment would apply for taxable periods starting on or after the date of enactment.





---

# Income tax remedials

---



## **BRIGHT-LINE TEST – CONSTRUCTION OF A MAIN HOME THAT TAKES LONGER THAN 12 MONTHS**

---

*(Clause 49)*

### **Summary of proposed amendment**

The proposed amendment to the main home exclusion from the bright-line test would ensure a main home that takes longer than 12 months to construct would not be subject to the bright-line test.

### **Application date**

The proposed amendment would apply to residential land acquired on or after 27 March 2021.<sup>9</sup>

### **Key features**

The proposed amendment to section CB 16A(6) would allow the period when a person is making reasonable efforts to construct a dwelling intended for use as their main home (or the main home of a beneficiary described in section CB 16A(2)) to be counted as “main home days” and not subject to the bright-line test. Upon completion of construction, the property would need to be used as the person’s main home for the construction period to count as “main home days”.

### **Background**

The main home exclusion from the bright-line test in section CB 16A applies where a property is the owner’s main home for the entire period it is owned, ignoring periods of less than 12 months where the property is not used as a main home. This 12-month buffer is intended to provide leeway for moving in or out of a property, or, for example, where the taxpayer rents out their home while they are overseas for a short period.

It was not intended that a taxpayer who purchases bare land and constructs their main home on the land would be subject to tax for the construction period if that is longer than 12 months. The proposed amendment to the main home exclusion would address this.

---

<sup>9</sup> However, it would not apply to property acquired on or after 27 March 2021 as a result of an offer made by the purchaser on or before 23 March 2021, provided the offer could not be revoked before 27 March 2021.

## **BRIGHT-LINE TEST – NO REDUCTION IF THE MAIN HOME EXCLUSION DOES NOT APPLY**

---

*(Clause 48)*

### **Summary of proposed amendment**

The proposed amendment would change the bright-line test so that the amount of income derived on the sale of a property used as a main home would not be reduced where the person has used the main home exclusion twice in a two-year period or has engaged in a regular pattern of acquiring and disposing of residential land.

### **Application date**

The proposed amendment would apply to residential land acquired on or after 27 March 2021.<sup>10</sup>

### **Key features**

Proposed changes amend section CB 6A(6) to provide that the formula in section CB 6A(7) does not apply to reduce the amount of income derived on disposing of property if the main home exclusion in section CB 16A does not apply because the person has already used the exclusion twice in the last two years or has engaged in a regular pattern of acquiring and disposing of residential land.

### **Background**

The income calculation provision in the bright-line test disregards any period of main home use (including certain periods of 12 months or less where the property is not used as the person's main home) where the main home exclusion does not apply (section CB 6A(7)). A person is only allowed to use the main home exclusion twice in a two-year period and if they are not engaged in a regular pattern of acquiring and disposing of residential land (section CB 16A(3)). The income calculation provision in the bright-line test disregards any period of main home use (as well as periods of 12 months or less where the property is not used as the owner's main home) where the main home exclusion does not apply (section CB 6A (7)). Where the main home exclusion does not apply because of section CB 16A(3), periods of main home use and non-main home use of 12 months or less should not be disregarded and should be included for the purposes of calculating income, otherwise the person could essentially access the main home exclusion more than twice in a two-year period.

---

<sup>10</sup> However, it would not apply to property acquired on or after 27 March 2021 as a result of an offer made by the purchaser on or before 23 March 2021, provided the offer could not be revoked before 27 March 2021.

**Example 25: Main home exclusion**

Bob purchases a house in January 2022, lives in it while he renovates it, and sells it in May 2022. He purchases another house in June 2022, lives in it while he renovates, and sells it in November 2022. He qualifies for the main home exclusion for both properties and pays no tax under the bright-line test (assume he is not subject to tax under any other taxing provision). He purchases his third property in January 2023, lives in it until May 2023 while he renovates it, then rents it until November 2023 before selling it. The main home exclusion would not apply to this third property as he has already used the exclusion twice in a two-year period. However, the current income calculation provision in the bright-line test would disregard the period where Bob lived in and renovated the property and the period where he rented the property, given it was under 12 months. This effectively allows him to claim the main home exclusion three times within a two-year period, which was not the policy intent.

## **BRIGHT-LINE TEST – CLARIFYING THE APPLICATION OF THE 12-MONTH BUFFER**

---

*(Clause 49)*

### **Summary of proposed amendment**

The proposed amendment to the main home exclusion from the bright-line test would clarify that:

- a person may still qualify for the exclusion if they have multiple periods, each of less than 12 months, where the property is not used as a main home, and
- a person may not use the reduction formula in the bright-line test or access the main home exclusion for a period of non-main home use exceeding 12 months by claiming that the period is multiple consecutive periods of less than 12 months

### **Application date**

The proposed amendments would apply to residential land acquired on or after 27 March 2021.<sup>11</sup>

### **Key features**

#### ***Multiple periods of less than 12 months***

The proposed amendment would change “a continuous period” to “one or more continuous periods” in section CB 16A(6)(b) to make it clear that a person could still qualify for the main home exclusion where they have multiple periods, each of less than 12 months, that do not meet the main home criteria.

#### ***Non-main home use exceeding 12 months***

In addition, the proposed amendment to section CB 16A(6)(c) would require both the beginning and end of such a period that does not meet the main home criteria to adjoin either a period within the bright-line period that meets the criteria, or the first or last day of the bright-line period, for the main home exclusion to apply. This amendment would prevent back-to-back continuous periods that are each less than 365 days but together exceed 365 days from satisfying the criteria, as each of these periods would be adjoined to the other. The land would still need to meet the criteria at some point in the bright-line period (existing section CB 16A(6)(a)). As a result, the continuous period would need to adjoin at least one period where there was use of the property as the main home to qualify.

---

<sup>11</sup> However, it would not apply to property acquired on or after 27 March 2021 as a result of an offer made by the purchaser on or before 23 March 2021, provided the offer could not be revoked before 27 March 2021.

## **Background**

### ***Multiple periods of less than 12 months***

The main home exclusion from the bright-line test in section CB 16A applies where a property is the owner's main home for the entire period it is owned, ignoring periods of less than 12 months where the property is not used as a main home. This 12-month buffer is intended to provide leeway for a taxpayer moving in or out of a property or, for example, renting out their home while they are overseas for a short period.

It is not clear from the current wording of the legislation whether the 12-month buffer period can be used only once or multiple times. The policy intent is that a person can qualify for the main home exclusion regardless of how many periods they do not satisfy the main home criteria, provided no individual period exceeds 12 months.

### ***Non-main home use exceeding 12 months***

The current wording also provides that a period where a property is not used as a main home is treated as satisfying the main home criteria if, among other things, the period is a continuous period of 365 days or less and the beginning or end of that period adjoins a period within the bright-line period where the property is used as a main home. Because only one end of the non-main home use period needs to adjoin a period where the property is used as a main home, arguably back-to-back periods that together exceed 365 days could qualify for the main home exclusion. For example, if a taxpayer used the property as their main home, then went overseas and rented the property first to person A for 250 days and then to person B for 250 days, and then used the property as their main home again, arguably they could still qualify for the main home exclusion because each of these periods is less than 365 days.

## **HYBRID AND BRANCH MISMATCHES – IMPORTED MISMATCH RULE**

---

*(Clauses 81, 82, and 127(10))*

### **Summary of proposed amendment**

The proposed remedial amendments address issues identified with the imported mismatch rule contained in the hybrid and branch mismatch rules (subpart FH of the Income Tax Act 2007).

### **Application date**

The proposed amendments would apply from 1 July 2018 (when the hybrid and branch mismatch rules generally applied from), except for amendment four, which would apply for income years beginning on or after the date of enactment.

### **Key features**

The proposed remedial amendments to the imported mismatch rule would:

1. Clarify that a deduction for a charge to a deducting branch in New Zealand is denied where the charge imports the benefit of an offshore mismatch into New Zealand.
2. Not deny a deduction (either wholly or partly) where a jurisdiction(s) in a chain of payments funding a mismatch has hybrid mismatch legislation.
3. Not deny a deduction where there is sufficient dual inclusion income for the payer of the funded payment.
4. Deny a deduction for payments that can be traced to a hybrid mismatch through loss grouping, group contributions of income, or consolidation.
5. Not deny a deduction for a payment that funds a mismatch where the mismatch is not due to hybridity.
6. Introduce two cross references into section YA 1 for terms defined in section FH 15(1) (“hybrid entity” and “hybrid mismatch”).

### **Background**

The New Zealand hybrid and branch mismatch rules were enacted in 2018 in response to the OECD reports *Neutralising the Effects of Hybrid Mismatch Arrangements – Action 2: 2015 Final Report*<sup>12</sup> (the Hybrid Mismatch Report) and *Neutralising the Effects of Branch Mismatch Arrangements – Action 2: Inclusive Framework on BEPS* (the Branch Mismatch Report). Issues have been identified in the imported hybrid and branch mismatch rules. In general, these issues arise where New Zealand’s rules do not align with the Hybrid Mismatch Report and the Branch Mismatch Report.

---

<sup>12</sup> OECD. (2015). *Neutralising the Effects of Hybrid Mismatch Arrangements, Action 2 – 2015 Final Report*, OECD/G20 Base Erosion and Profit Shifting Project, OECD Publishing, Paris at [234].



New Zealand’s hybrid and branch mismatch rules seek to remove the tax benefit from various hybrid and branch mismatch arrangements. Hybrid and branch mismatch arrangements are cross-border arrangements that exploit differences in the tax treatment of an instrument, entity or branch under the laws of two or more countries to eliminate, defer or reduce income tax.

All of the proposed remedial amendments in this section concern the imported mismatch rule. The imported mismatch rule generally denies deductions for payments made by New Zealand taxpayers where the payments fund a “hybrid mismatch” located offshore. The imported mismatch rule therefore prevents the benefit of the hybrid or branch mismatch being imported to New Zealand. It is the most complex of the hybrid rules, and for that reason, it only became fully effective for tax years beginning on or after 1 January 2020.

## Detailed analysis

### *Denying deductions for charges that import the benefit of a hybrid mismatch into New Zealand*

The proposed rewrite of current sections FH 11(1) and FH 11(1B) would clarify that deductions generated by charges to branches<sup>13</sup> in New Zealand can be denied under the imported mismatch rule where the charge shifts the benefit of a hybrid mismatch into New Zealand. The introduction to the imported mismatches chapter of the Hybrid Mismatch Report provided that:

The policy behind the imported mismatch rule is to prevent taxpayers from entering into structured arrangements or arrangements with group members **that shift the effect of an offshore hybrid mismatch into the domestic jurisdiction** through the use of a non-hybrid instrument such as an ordinary loan. The imported mismatch rule **disallows deductions for a broad range of payments (including interest, royalties, rents and payments for services) if the income from such payments is set-off, directly or indirectly, against a deduction that arises under a hybrid mismatch arrangement in an offshore jurisdiction** (including arrangements that give rise to DD outcomes). The key objective of [the] imported mismatch rule is to maintain the integrity of the other hybrid mismatch rules by removing any incentive for multinational groups to enter into hybrid mismatch arrangements. [Emphasis added.]

While it is arguable that section FH 11 already denies a deduction for a charge, the proposed new language seeks to clarify the position.

Proposed new section FH 11(1) would replace the opening text of the current section, which describes the payment or charge for which a deduction can be denied under the imported mismatch rule. The subsection excludes payments to, or charges made by, a person in a country that has hybrid mismatch legislation.

Proposed paragraphs (a) and (d)–(g) of section FH 11(1B) would replace current paragraphs (a)–(e) of section FH 11(1) respectively. Table 2 provides details about each paragraph of the proposed section.

---

<sup>13</sup> Typically, charges to branches are for cost of goods sold or interest on a notional loan.

**Table 2: Commentary on proposed paragraphs (a)–(g)**

<b>Paragraph(s)</b>	<b>Comment</b>	<b>Equivalent current paragraph</b>
(a)	Proposed paragraph (a) requires that the original payment or charge provides funds for a payment (the funded payment). Whether a payment or charge “provides funds” for a funded payment is determined consistently with the approaches described in chapter 8 of the Hybrid Mismatch Report and chapter 5 of the Branch Mismatch Report (see proposed section FH 11(5)). <sup>14</sup>	Paragraph (a)
(b) and (c)	These are new paragraphs and are described under “Chains of payments through jurisdictions with hybrid mismatch legislation”.	None
(d) and (e)	Proposed paragraphs (d) and (e) implement minor amendments to current paragraphs (b) and (c) to ensure they apply correctly to charges.	Paragraphs (b) and (c)
(f)	Proposed paragraph (f) relies on the new definition of “hybrid mismatch”. This new definition is described further under the heading “Limiting the rule to mismatches arising from hybridity” below.	Paragraph (d)
(g)	Proposed paragraph (g) replicates current paragraph (e) but removes reference to the payer jurisdiction. With the new definition of “hybrid mismatch”, that reference is now unnecessary. (For more details see “Limiting the rule to mismatches arising from hybridity”.)	Paragraph (e)

### ***Chains of payments through jurisdictions with hybrid mismatch legislation***

The imported mismatch rule can apply through a chain of any number of payments, any number of jurisdictions and in any direction (that is, up or down a corporate chain, or sideways). The imported mismatch rule currently does not apply to a payment where any of the following persons are in a jurisdiction that has hybrid mismatch legislation:

- the recipient of the payment from the New Zealand funder
- the person who makes the payment that constitutes the hybrid mismatch (located offshore), or
- except in the case of a double deduction mismatch, the person who receives the payment that constitutes the hybrid mismatch (located offshore).

Under the proposed amendments to clarify the application of the imported mismatch rule to charges, the rule would also not apply where a non-resident who makes a charge is located in a jurisdiction with hybrid mismatch legislation.

In all these cases, any denial of a deduction in New Zealand would result in over-taxation. This is because the other jurisdiction with hybrid mismatch legislation would have first priority to either deny deductions or recognise income to counteract the benefit of the

<sup>14</sup> However, section FH 11(5) would only apply for income years beginning on or after the date of enactment.

mismatch. However, another jurisdiction (other than those above) through which the chain of payments flows may have hybrid mismatch legislation with an imported mismatch rule that would deny deductions to address the mismatch. Further denial of deductions in New Zealand would result in the denial of two sets of deductions in respect of one mismatch and result in over-taxation.

To prevent this over-taxation, the proposed amendment would ensure the imported mismatch rule only denied deductions in New Zealand for a payment that provides funds to the funded payment where:

- First, the funds are provided to the payer either directly or indirectly through a series of further transactions (the **intermediate transaction chain**) that are each governed by the tax laws of countries or territories outside New Zealand (proposed section FH 11(1B)(b)). An intermediate transaction chain only comprises transactions further to (that is, other than) the original payment or charge and the funded payment. An intermediate transaction chain could comprise of simply one transaction.
- Second, for each transaction in an intermediate transaction chain, each country or territory with tax laws that govern the transaction does not have hybrid mismatch legislation having an intended effect corresponding to section FH 11 (proposed section FH 11(1B)(c)).

In effect, where there is only one intermediate transaction chain and a country governing a transaction along that chain is subject to hybrid mismatch legislation, then the imported mismatch rule would not apply to deny deductions. However, where an original payment or charge provides funds through multiple intermediate transaction chains to the funded payment, the deduction for the original payment or charge could be denied provided that **at least one chain** of transactions satisfies section FH 11(1)(b) and (c).

*New Zealand providing funds to funded payment through a single intermediate transaction chain*

Under the proposed section FH 11(1B), where the original payment or charge provide funds for the funded payment through a **single** intermediate transaction chain, and **at least one of those transactions** in the intermediate transaction chain is governed by a country or territory with an imported mismatch rule, then the deduction for the original payment or charge would not be denied in New Zealand. This is demonstrated in example 26.

**Example 26**

*Facts*

- A Co, B Co, C Co, D Co, and NZ Co are members of a control group. There is a D/NI outcome (hybrid mismatch) between A Co and B Co – there is a deduction created in Country B, without corresponding income in Country A.
- NZ Co makes a payment to D Co, which provides funds indirectly through transactions (the intermediate transaction chain) from D Co to C Co and from C Co to B Co, to the funded payment (hybrid mismatch) between B Co and A Co.
- C Co is located in Country C, which has hybrid mismatch legislation having an intended effect corresponding to New Zealand’s imported mismatch rule (hence it is shaded). Countries A, B and D do not have hybrid mismatch legislation.

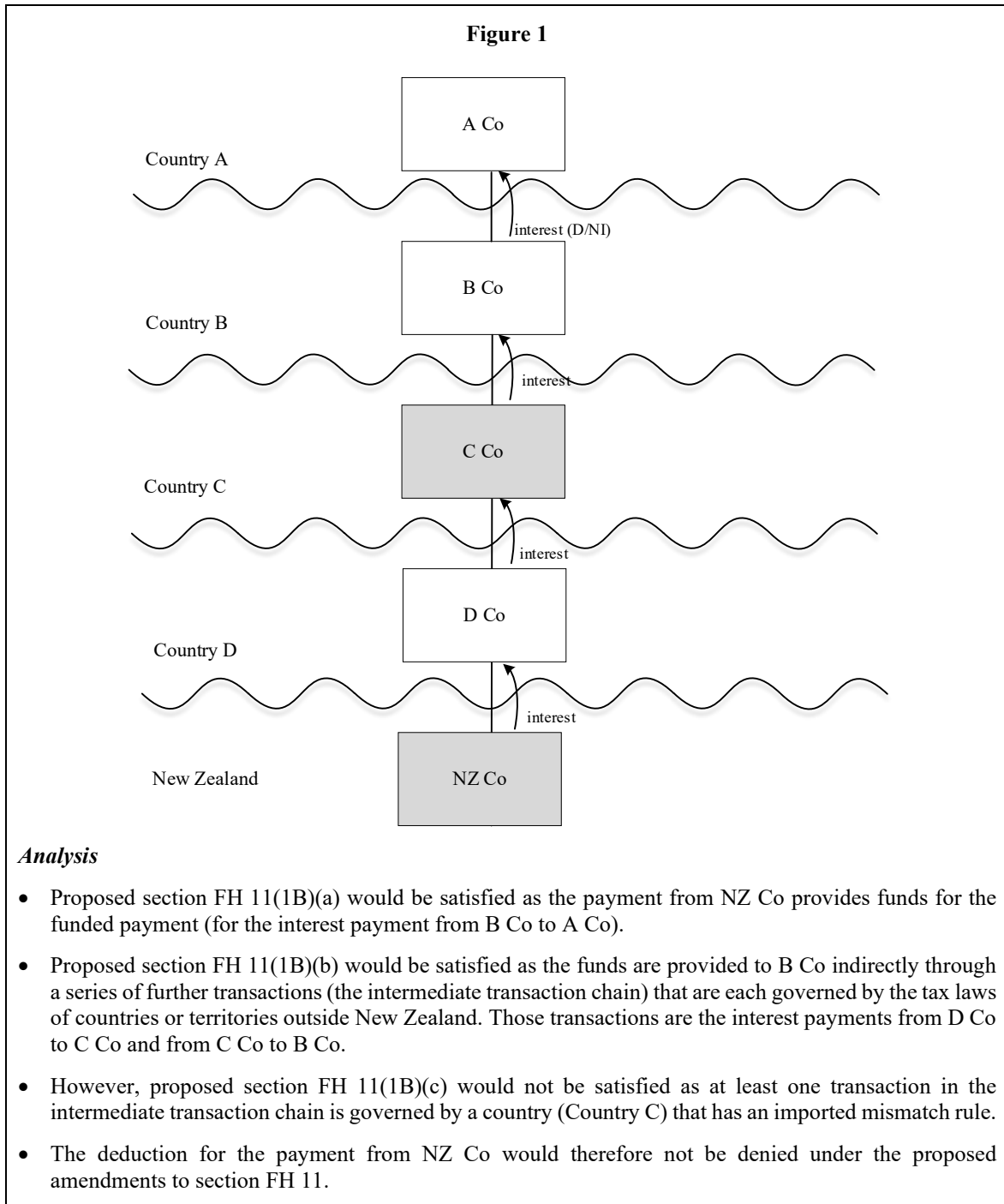

*New Zealand providing funds to funded payment through multiple intermediate transaction chains*

Where the original payment or charge can be said to provide funds indirectly to the funded payment through **multiple** intermediate transaction chains, and **one** of those chains contains a transaction that is governed by a country or territory with an imported mismatch rule, then the deduction for the original payment or charge could (to some extent) still be denied on the basis that the original payment or charge provides funds indirectly through other intermediate transaction chains to the payer for the funded payment.

However, the extent to which such a deduction is denied would depend on sections FH 11(4) and (5). This includes first considering whether there is dual inclusion income in the payer

jurisdiction<sup>15</sup> and then second considering the tracing and priority rules provided in the Hybrid Mismatch Report and the Branch Mismatch Report (as is done under current legislation). The extent of the denial under New Zealand's imported mismatch rule may depend on, for example, whether priority to deny a deduction is given to another country's imported mismatch rule (for example, where another country is more proximate to the hybrid mismatch and triggers the direct imported mismatch rule) and therefore deductions in New Zealand should be partly or wholly allowed. This is demonstrated in example 27.

**Example 27**

**Facts**

- The facts are the same as in example 26 except that D Co also makes a direct interest payment to B Co.

**Figure 2**

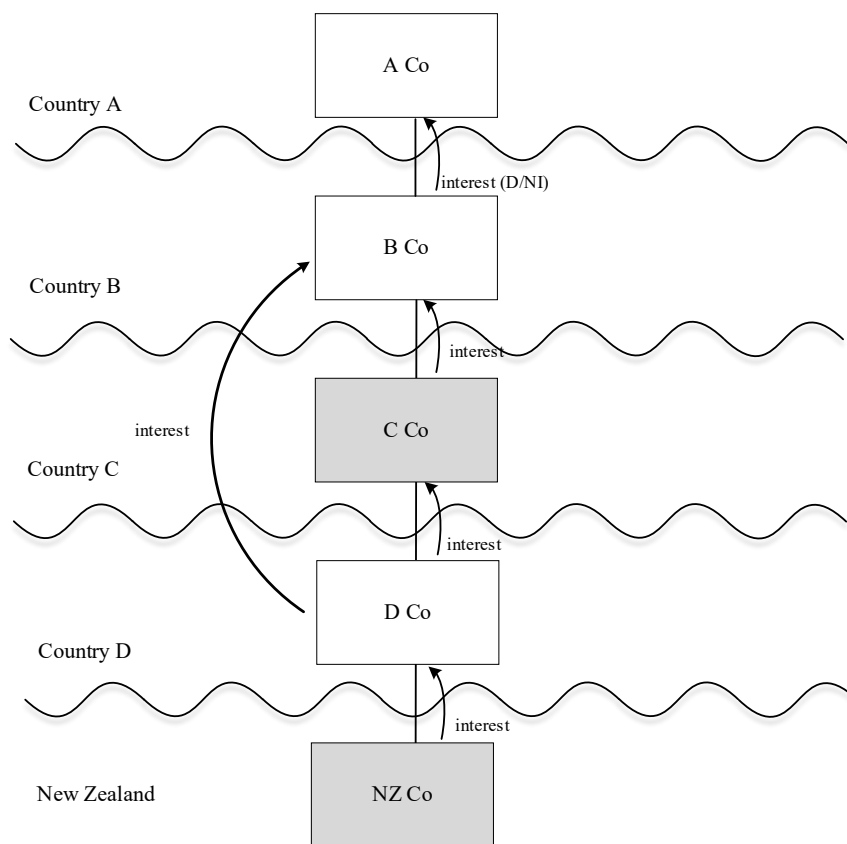

**Analysis**

- Proposed section FH 11(1B)(a) would be satisfied as the payment from NZ Co provides funds for the funded payment (from B Co to A Co).
- Proposed section FH 11(1B)(b) would be satisfied as the funds are provided to B Co indirectly through a series of further transactions (the intermediate transaction chain) that are each governed by the tax laws of countries or territories outside New Zealand. Here, NZ Co provides funds indirectly through **two** intermediate transaction chains:
  - **Chain 1:** From D Co to C Co and from C Co to B Co (to the hybrid mismatch between B Co and A Co).

<sup>15</sup> See the heading "Imported mismatches and dual inclusion income", describing an amendment to provide that deductions should not be denied under New Zealand's imported mismatch rule to the extent a 'hybrid payment' (in New Zealand, a 'funded payment') is set off against dual inclusion income in the payer jurisdiction.

- **Chain 2:** From D Co to B Co (to the hybrid mismatch between B Co and A Co).
- Proposed section FH 11(1B)(c) would be satisfied where **for each** transaction in **at least one** of the intermediate transaction chains described above, **each** country or territory with tax laws that govern the transaction does not have an imported mismatch rule.
  - **Chain 1:** Country C governs both of the transactions that comprise Chain 1. Country C has an imported mismatch rule, so paragraph (c) is not satisfied in respect of Chain 1.
  - **Chain 2:** Countries B and D govern the single transaction that comprises Chain 2. Neither of Countries B or D have an imported mismatch rule, so paragraph (c) is satisfied.
- Provided all other requirements in section FH 11(1B) are met, then section FH 11(2) will deny a deduction in New Zealand for an amount (which could be zero).
- The amount of those denied deductions (if any) is determined according to sections FH 11(3)-(5) as appropriate. This includes using the tracing and priority rules as provided in the Hybrid Mismatch Report and Branch Mismatch Report.
  - In this example, the direct imported mismatch rule provided in the Hybrid Mismatch Report would require that Country C first deny the deductions.
  - If the direct imported mismatch rule as applied by Country C does not fully neutralise the effect of the mismatch, then deductions for the original payment or charge would be denied in New Zealand sufficient to neutralise the effect of the mismatch.

### ***Tracing through loss grouping, group contributions of income, and consolidation***

Proposed section FH 11(5) is intended to allow tracing through tax grouping regimes. The proposed subsection provides that whether a payment or charge by a funder “provides funds” for a funded payment under section FH 11(1B)(a) is determined consistently with the approaches described in chapter 8 of the Hybrid Mismatch Report and chapter 5 of the Branch Mismatch Report. This would include determining whether there is a chain of payments (that is, an intermediate transaction chain) that establishes the original payment or charge provides funds indirectly to the funded payment.

Those report chapters provide various methods for determining the payments that can be traced out from the hybrid mismatch and subsequently denied under an imported mismatch rule; such payments being called “hybrid deductions”. This essentially provides a method for tracing chains of payments from a hybrid mismatch out to, for example, New Zealand. A “hybrid deduction” is described in the Hybrid Mismatch Report (at [243]) as including hybrid deductions that are “surrendered to a group member under a tax grouping regime”. Further, examples 8.10 and 8.14 in the Hybrid Mismatch Report provide examples of the effect of such loss surrendering and the required tracing method.

Proposed section FH 11(5) is intended to include any type of tax grouping regimes, including loss grouping, income grouping (under regimes providing for group contributions of income), and consolidation regimes. The amount by which the New Zealand original payment or charge funds the funded payment is to be determined consistently with the Hybrid Mismatch Report.

An example of the application of proposed section FH 11(5) is demonstrated in example 28.

## Example 28

Figure 3

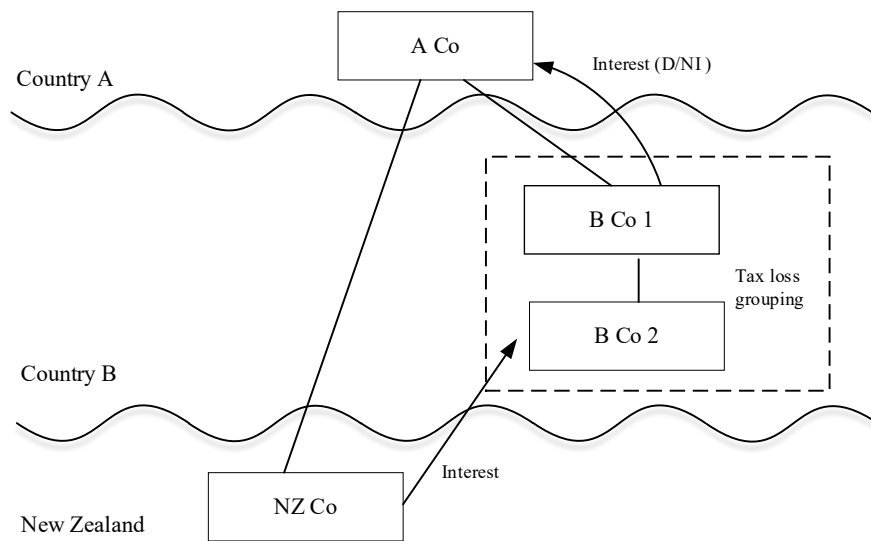

Tax loss grouping in Country B allows the benefit of the D/Ni outcome to erode the New Zealand tax base:

- There is a D/Ni outcome between A Co and B Co 1 – a deduction created in Country B, without corresponding income in Country A.
- The tax loss grouping available in Country B allows B Co 1’s loss (generated from the deduction from the D/Ni outcome) to be offset against B Co 2’s income (generated from the payment from NZ Co). The payment from NZ Co to B Co 2 generates a deduction in New Zealand.
- Overall, deductions are generated in New Zealand with no income elsewhere in the world. No income is generated in Country A, the income and deductions in Country B offset each other, and a deduction is generated in New Zealand.

Similar analysis applies where B Co 1 and B Co 2 are subject to a consolidation regime or where a group contribution of income from B Co 2 to B Co 1 is allowed.

### *Imported mismatches and dual inclusion income*

The Hybrid Mismatch Report indicates that deductions should not be denied under the imported mismatch rule to the extent a “hybrid payment” (in New Zealand, a “funded payment”) is set off against dual inclusion income (similar to surplus assessable income in section FH 12). New Zealand’s imported mismatch rule partially implements this through current section FH 11(3)(b) for structured arrangements.

The amount of a denied deduction under section FH 11(3)(b) is equal to the amount of the funded payment that, if hybrid mismatch legislation were applied by the payer jurisdiction, would be disallowed as a deduction against income or equivalent tax relief. In other words, if the payer jurisdiction applied a dual inclusion income rule and some or all of the deductions in the payer jurisdiction would not be denied in such a situation, then some or all of the deductions in New Zealand under the imported mismatch rule would also not be denied.

However, section FH 11(3)(b) only applies for structured arrangements (being arrangements priced assuming the existence of a hybrid or intended to rely on, or produce, a hybrid). No similar rule exists for unstructured arrangements.

Proposed section FH 11(4) would provide a test for unstructured arrangements similar to that provided in section FH 11(3)(b).

Proposed section FH 11(5) would allow a carry forward of denied deductions to a later year when there is excess dual inclusion income. It provides that a deduction denied under the imported mismatch rule is allowed in a later income year to the extent that:

- the payer jurisdiction would allow a deduction for the funded payment in the later income year if hybrid mismatch legislation were applied by the payer jurisdiction
- the funded payment is funded by the denied deduction, and
- the denied deduction meets the requirements of section FH 12(8) to be carried forward to the later income year as a mismatch amount.

The amount allowed in New Zealand is proportional to the amount of deduction that is allowed in the payer jurisdiction. For example, assume the funded payment (hybrid mismatch) was \$100, of which New Zealand funded \$50 (that is, 50%). If \$80 of dual inclusion income arose in a later year, the payer jurisdiction would allow a deduction in that year of \$80. Given that the extent of New Zealand's funding of the funded payment (hybrid mismatch) was 50%, then a \$40 deduction would be allowed in New Zealand ( $\$50 \times \$80/\$100 = \$40$ ).

### ***Limiting the rule to mismatches arising from hybridity***

The current definition of “hybrid mismatch” could deny deductions for New Zealand payments that fund offshore payments that receive different tax treatments in different jurisdictions for reasons other than hybridity. For example, the jurisdiction receiving the hybrid payment may have no corporate income tax regime or have a territorial tax regime. Denying deductions in these situations is inconsistent with the intention of the Hybrid Mismatch Report, which was to only address mismatches that arise due to the different tax characterisations of instruments or entities.

The proposed new definition of “hybrid mismatch” is intended to mitigate these concerns by using New Zealand's hybrid and branch mismatch rules to determine whether a payment from a jurisdiction (the payer jurisdiction) is a hybrid mismatch. If an amount of a deduction for a payment would be denied by the payer jurisdiction if that jurisdiction had legislation having an effect corresponding to New Zealand's hybrid and branch mismatch rules, then a hybrid mismatch arises. Practically, this would essentially require consideration of whether the deduction would be denied under New Zealand's hybrid and branch mismatch rules if the payer was in New Zealand.

Following, if the payer jurisdiction does, in fact, have hybrid mismatch legislation that counteracts the relevant mismatch in that jurisdiction, then no deduction exists in the payer jurisdiction, and therefore no “hybrid mismatch” will arise for the purposes of New Zealand's imported mismatch rule. As a result of this proposed new approach, references to counteraction by the payer jurisdiction in current section FH 11(1)(e) would be removed in the proposed equivalent section FH 11(1B)(g).

### ***Cross-references to definitions***

Proposed cross-references from section YA 1 to the definitions of “hybrid entity” and “hybrid mismatch” in section FH 15(1) are to improve readability. No change of interpretation or meaning of those provisions is intended.



## **EARLY-PAYMENT DISCOUNT RATE CHANGES**

---

*(Clause 111)*

### **Summary of proposed amendment**

The proposed amendment would alter the rate of the early-payment discount (EPD) from 6.7% to match the use of money interest (UOMI) credit rate plus 200 basis points.

### **Application date**

The proposed amendment would apply from the date of enactment.

### **Background**

The EPD is intended to encourage early payment of provisional tax to relieve the financial strain associated with having to pay both terminal tax and provisional tax in the second year of business.

The EPD rate was set at 6.7% when it was introduced in 2005 and has not been updated since. Consequently, it now represents a windfall for qualifying taxpayers. This change would align the EPD rate with the UOMI credit rate plus 200 basis points. The EPD would therefore retain its purpose of incentivising the early payment of provisional tax without representing a windfall for the taxpayers who use it.

## RESTRICTED TRANSFER PRICING REMEDIALS

---

*(Clauses 51 and 86)*

### **Summary of proposed amendment**

Two proposed remedial amendments to the restricted transfer pricing rules would:

- Ensure the deemed dividend arising when interest is disallowed under the restricted transfer pricing rules is calculated based on the amount disallowed under those rules rather than the arm's length amount.
- Ensure the third-party test for loans with terms of more than five years applies only when there is significant third-party borrowing with terms of more than five years.

### **Application date**

The proposed deemed dividend amendment would apply for income years starting on or after 1 April 2022. The proposed five-year term amendment would apply from 1 July 2018.

### **Key features**

#### ***Deemed dividend***

When interest is denied under the transfer pricing rules, the additional amount above the arm's length amount is treated as a deemed dividend. However, in some circumstances, applying the restricted transfer pricing rules results in more interest than the arm's length amount being denied. As the legislation does not contemplate this, the difference between the arm's length interest and the allowable interest under the restricted transfer pricing rules retains its status as interest (albeit non-deductible to the borrower).

The proposed changes would amend the rules so that the amount of a deemed dividend is calculated by comparing the actual amount of interest paid with the lower of the amount determined under ordinary transfer pricing rules and the amount determined under the restricted transfer pricing rules.

#### ***Third-party test for loans of more than five years***

The third-party test to allow terms of more than five years when there is significant third-party borrowing with terms of more than five years currently compares the relevant individual cross-border related borrowing with borrowing from third parties. Proposed changes would amend this test so it compares the amount of all cross-border related borrowing with borrowing from third parties.

## Detailed analysis

### *Deemed dividend*

The general transfer pricing rules in sections GC 6 to GC 14 deny deductions for interest payments for cross-border related-party loans where the interest rate is above the rate for arm's length conditions that would be agreed to by a third party in a comparable transaction.

The restricted transfer pricing rules in sections GC 15 to GC 19 also apply to certain related-party loans between non-resident lenders and New Zealand resident borrowers. The rules alter the terms and conditions of a borrower and/or a loan before the general transfer pricing rules are applied to price the interest.

When interest is denied under the transfer pricing rules, the additional amount above the arm's length amount is treated as a deemed dividend by sections CD 39(5) and CD 39(8).

In some circumstances, such as where there are uncommercial terms or conditions are being ignored, the restricted transfer pricing rules deny an additional amount of interest that would fall within the arm's length amount. However, as section CD 39(8) does not contemplate this, the difference between the arm's length interest and the allowable interest under the restricted transfer pricing rules retains its status as interest (albeit as non-deductible to the borrower). Therefore, the amount of denied interest and the deemed dividend do not match.

The proposed amendment would change section CD 39(8) so that the amount of a deemed dividend would be determined by comparing the actual amount of interest paid with the lower of the amount determined under the ordinary transfer pricing rules and the amount determined under the restricted transfer pricing rules.

### *Third-party test for loans of more than five years*

The Taxation (Annual Rates for 2020–21, Feasibility Expenditure, and Remedial Matters) Act 2021 amended section GC 18(4) to introduce a second method to allow a cross-border related borrowing to have a term of more than five years. This is provided the term of cross-border related borrowing is less than the weighted average term of third-party borrowing. As with other parts of the restricted transfer pricing rules, this is only available when there is significant third-party debt. The reason for this is to prevent a borrower having a small amount of expensive third-party debt and using that to justify a large amount of expensive related-party debt.

As enacted, the amendments to section GC 18(4) allow terms of more than five years when the amount of the cross-border related borrowing is less than four times the amount of third-party borrowing. However, this test applies to **each** cross-border related borrowing at the time the interest rate is being determined. This makes it possible for a borrower to have multiple cross-border related borrowings that are each individually below the four-times threshold but, when viewed collectively, are above the threshold. This was not intended.

The proposed amendment would change section GC 18(4)(b)(ii) so that the relevant test would be applied to the total value of all cross-border related borrowing rather than the specific cross-border related borrowing for which the terms and interest rate are being determined.

## DEPRECIATION COST BASE INTEGRITY MEASURE

---

*(Clause 67)*

### **Summary of proposed amendment**

The proposed amendment to the depreciation cost base integrity measure in section EE 40 would ensure it applies to non-residential buildings that were transferred to an associate when depreciation on non-residential buildings was 0%.

### **Application date**

The proposed amendment would apply for the 2011–12 and later income years.

### **Key features**

The proposed amendments to sections EE 40(2) and EE 40(3) would ensure that the depreciation cost base restriction in section EE 40(7) would apply where an associated vendor would have been allowed a deduction for an amount of depreciation loss for a non-residential building if the depreciation rate had not been 0%.

### **Background**

The cost base that may be used for depreciation purposes where a purchaser has acquired depreciable property from an associated vendor is restricted to the cost of the property to the associate under section EE 40(7). This is an integrity measure to prevent the purchaser from claiming more depreciation than was available to the associated vendor.

The restriction applies where the associated vendor was allowed a deduction for an amount of depreciation loss for the item either in the year it was transferred to the purchaser or in the previous income year (sections EE 40(2) and EE 40(3)).

Non-residential buildings were depreciable at a rate of 0% from the 2011–12 income year until the start of the 2020–21 income year.

Therefore, it is arguable that the cost base restriction does not apply to a non-residential building sold to an associate during the years where non-residential buildings were depreciable at 0%, as the associated vendor was not allowed a deduction for an amount of depreciation loss for the building.

It was not intended that the cost base restriction would not apply because depreciation rates were set at 0%.

## **FOREIGN CURRENCY LOANS THAT FINANCE RESIDENTIAL RENTAL PROPERTY IN A FOREIGN JURISDICTION**

---

*(Clause 70)*

### **Summary of proposed amendment**

The proposed amendment would amend the definition of “residential income” to include income that a person derives from a foreign currency loan to the extent the loan finances their residential portfolio.

### **Application date**

The proposed amendment would apply for income years beginning on or after the date of enactment.

### **Key features**

Under the proposed amendment, income that a person derives from a foreign currency loan under section CC 3 (Financial arrangements) would be residential income, for the purposes of section EL 3, to the extent the loan finances their residential portfolio.

### **Background**

Deductions relating to a foreign currency loan that finances a residential rental property, including foreign exchange losses, are ring-fenced by section EL 4. However, foreign exchange gains on the same loan in a subsequent period cannot be offset against the ring-fenced deductions because this income is not included in the definition of “residential income” in section EL 3. The proposed amendment to the definition is intended to address this issue.

## **FRINGE BENEFIT TAX – UNCLASSIFIED BENEFITS PAID BY ASSOCIATES**

---

*(Clause 114)*

### **Summary of proposed amendment**

The proposed changes would amend the unclassified benefits de minimis concession for fringe benefit tax (FBT). The amendment would exclude unclassified benefits paid by an employer's associate to that associate's employees from the calculation of the de minimis concession when the employer and their associate are not part of the same commonly owned group (as defined in section IC 3).

### **Application date**

The proposed amendment would apply for the 2022–23 and later income years. This would be from 1 April 2022, except for employers calculating FBT on an income year basis.

### **Key features**

The proposed amendment would exclude unclassified benefits paid by an employer's associate to that associate's employees from the calculation of the de minimis concession when the employer and their associate are not part of the same commonly owned group (as defined in section IC 3).

### **Background**

Section RD 45 provides that if the amount of unclassified benefits provided by an employer falls below a de minimis, then FBT does not apply. An employer is only liable to pay FBT on unclassified benefits if they exceed \$300 per individual employee per quarter or \$22,500 of total benefits in four consecutive quarters.

Existing section RD 45(6) expands the meaning of “employer” to include persons “associated” with the employer within the relevant period. This is intended to prevent benefits being provided by an associated employer or to employees of an associate, rather than directly, to effectively increase the amount of unclassified benefits being paid without being over the de minimis.

However, benefits paid by an associate to that associate's employees, even when the employer has no connection with or oversight of that associate, must also be taken into account when determining whether the de minimis in section RD 45 applies. These benefits are also less likely to be provided to avoid the de minimis.

### **Detailed analysis**

Proposed new section RD 45 would clarify the categories of unclassified benefits that an employer must take into account when determining if they are liable to pay FBT. The existing categories that have been included in proposed new subsection (4) are:

- unclassified benefits provided by an employer to their employee
- unclassified benefits provided by persons associated, at any time in the relevant period, with the employer to employees of the employer, and
- unclassified benefits provided by the employer to employees of persons associated, at any time in the relevant period, with the employer.

The proposed new category that would apply if the employer is a company:

- Unclassified benefits provided by other companies that are part of the same group of companies as the employer, at any time in the relevant period, to employees of those other companies.

This category would remove the need for an employer to consider unclassified benefits provided by an associate to the associate's own employees.

## **ELECTION DAY WORKER TAX CODE**

---

*(Clause 127(6))*

### **Summary of proposed amendment**

The proposed amendment would change the current definition of “election day worker” to extend access to the election day worker tax code to advance voting workers.

### **Application date**

The proposed amendments would apply from 1 April 2022.

### **Key features**

The proposed amendment would change paragraph (c) of the definition of “election day worker” in section YA 1 of the Income Tax Act 2007 so that it would apply to a person who works on any days on which voting is held in New Zealand for an election or poll. This would replace the current definition that only applies to a person who works on election day.

The terms “Deputy Returning Officer” and “poll clerk” in paragraph (a) of the definition are no longer being used by the Electoral Commission, so the proposed amendment would replace these with “electoral official” in line with current practice.

### **Background**

Election day workers are taxed through the PAYE system at a flat rate of 17.50 cents in the dollar (plus ACC earner’s levy). The rationale for this flat rate of PAYE was to simplify withholding for the Electoral Commission in dealing with a temporary work force.

The current definition of election day worker applies to “work done or services rendered immediately before, on, or immediately after the day on which the election or poll is held”. However, this definition has been outpaced by both the growth in advance voting and the fact that many election workers work throughout the voting period.

The proposed amendments to the definition would align with the current electoral process.

### **Detailed analysis**

The issue with the current definition is that the work done or services rendered must be immediately before, on, or immediately after election or polling day. Advance voting can take place several weeks before the election or polling day and so most of the work associated with advance voting would not meet the current definition.

The proposed amendment would decouple the definition from the election day or polling day and links it to days on which voting is held instead. This would capture those workers who work immediately before, on, or immediately after days where voting, including advance voting, takes place.



The proposed amendment would also specify that the work must be for voting held in New Zealand, as otherwise the definition may cover workers hired to facilitate overseas voting. These workers are not intended to be covered, so this addition is proposed to avoid confusion.

## APPROVED ISSUER LEVY AND SECURITY TRUSTS

---

### *(Clause 119)*

#### **Summary of proposed amendment**

The proposed amendment would ensure that approved issuer levy (AIL) can still be paid where the approved issuer and the lender are only associated through a security trust.

#### **Application date**

The proposed amendment would apply from 30 March 2017, the date section RF 12(1)(a)(iv) came into effect.

#### **Key features**

The proposed remedial amendment to section RF 12(1)(a)(iv) would ensure that AIL can still be paid where the approved issuer and the lender are only associated through a security trust.

#### **Background**

Under section RF 12, a borrower can pay AIL at the rate of 2% on interest payments to non-residents under registered securities. This is instead of withholding non-resident withholding tax (NRWT) at the rate of 15%. AIL is only available if (among other things) the borrower and the lender are not associated (as determined under the general associated person rules). However, section RF 12(1)(a)(ii) provides that AIL is still available if the parties are only associated because the lender is a beneficiary of a trust established for the main purpose of protecting and enforcing beneficiaries' rights under the registered security (referred to as a security trust).

This exception was included because security trusts are often used for bond issues and the limited rights they provide to the bond holders do not create the kind of commonality of interest that the associated person rules were intended to capture. Accordingly, it is appropriate for AIL to still be payable on bond issues that use a security trust to protect the rights of otherwise non-associated bond holders.

However, the Income Tax Act 2007 was amended in 2017 by inserting section RF 12(1)(a)(iv). That section extended AIL unavailability for "related party debts" (as defined in section RF 12H), which includes loans between associated persons. Associated persons for this purpose would include those associated through a security trust. The consequence is that the requirement in section RF 12(1)(a)(iv) that a loan not be a "related party debt" effectively over-rides the exclusion from association for security trusts in section RF 12(1)(a)(ii), making that exclusion ineffective. This was not intended.

Therefore, the proposed amendments to section RF 12(1)(a)(iv) would restore the effectiveness of the exclusion in section RF 12(1)(a)(ii). This would allow AIL to still be paid where the borrower and lender are only associated because the lender is the beneficiary

of a security trust. Section RF 12(1)(a)(iv) would still prevent AIL from being payable if the registered security is a related party debt for other reasons.

## ELECTING INTO THE SECURITISATION REGIME

---

*(Clause 89)*

### **Summary of proposed amendment**

The proposed amendment would allow taxpayers to elect into the securitisation regime from the commencement of their securitisation arrangement.

### **Application date**

The proposed amendment would apply from the date of enactment.

### **Key features**

The proposed amendment to section 9BA(1) would allow originators to elect into the securitisation regime from the commencement of their securitisation arrangements, rather than when their tax returns are filed.

### **Background**

The Income Tax Act 2007 contains a specific regime for securitisations in sections 9B–9C and sections 9D–9E. Under this regime, the originator of debt assets is treated as still owning them for tax purposes following their transfer to a special purpose vehicle (SPV). This allows the SPV to be tax neutral (that is, have no net tax obligations). The securitisation regime requires the originator, rather than the SPV, to satisfy all the tax obligations relating to the transferred debts. This means the originator must withhold and pay any non-resident withholding tax (NRWT) or approved issuer levy (AIL) on the interest payments by the SPV.

Currently, an originator elects into the securitisation regime when it files its tax return for the relevant income year (section 9B), and the election then has effect for that year. For NRWT and AIL (which are usually payable monthly), the election effectively applies retrospectively to the start of the income year. This was intended to avoid the need for a separate election process and reduce compliance costs. However, relying on the originator to elect into the securitisation regime in its tax return for the year exposes the SPV to the risk of unpaid tax (plus interest and penalties) if the election is not made. This risk has led to the securitisation regime being underused.

To address this, the proposed amendment would allow the originator to elect into the securitisation regime from the commencement of the securitisation arrangement.

## TAX POOLING AND EARLY-PAYMENT DISCOUNT SETTINGS

---

*(Clauses 112, 124, and 126)*

### **Summary of proposed amendment**

The four proposed remedial amendments to tax pooling and early-payment discount (EPD) settings would:

- allow the use of tax pooling funds to mitigate use of money interest (UOMI) in the first year as a provisional taxpayer
- allow purchased tax pooling funds to qualify for the EPD
- restore the link between sections RP 19(2) and RP 19(3) of the Income Tax Act 2007 (ITA), and
- extend the definition of small-business person to include the shareholder of a look-through company (LTC).

### **Application date**

The proposed amendments would apply from the date of enactment.

### **Background**

#### ***Mitigating UOMI***

Under current settings, non-safe harbour taxpayers (those with residual income tax of more than \$60,000) cannot use purchased tax pooling funds to mitigate UOMI in their first year as a provisional taxpayer. This is contrary to the policy intention.

The availability of tax pooling is intended to reduce exposure to UOMI if there is uncertainty over the correct tax liability at the due date. As tax pooling is limited to satisfying taxpayer “obligations” (section RP 17) and initial provisional taxpayers are not “obliged” to pay provisional tax (section RC 3(3)), they cannot use purchased tax pooling funds to reduce their exposure to UOMI. Although section RP 17 now includes an obligation to pay terminal tax, the relevant credit date in section RP 19(3)(a), being the due date for terminal tax, is not early enough to affect the UOMI exposure from provisional tax installment due dates.

#### ***Use of tax pooling to get the early payment discount***

In 2009, tax pooling was extended beyond provisional tax to include terminal tax. Consequently, a taxpayer who has no obligation to pay provisional tax (and therefore may qualify for an EPD) will still have an obligation to pay terminal tax, and tax pooling can be used to meet an obligation to pay that terminal tax (section RP 17).

Such taxpayers qualify for the EPD if their income tax is paid before balance date and they can use their own deposited tax pooling funds to qualify for the discount. This is on the basis that tax pooling can be used to meet an obligation to pay terminal tax, and for own deposited funds, the credit date under section RP 19(3) is the date the funds were deposited.

However, the earliest credit date for purchased funds is the terminal tax date, so purchased funds would not qualify for the EPD.

Previously, non-safe harbour taxpayers were generally able to use tax pooling and were credited with an EPD. However, following Inland Revenue's Business Transformation, a transfer with a backdated effective date is no longer recognised for the purposes of the EPD if the date the transfer is processed is after the taxpayer's balance date. The proposed amendment would bring the legislation in line with previous practice. This is considered the right policy outcome.

### ***Aligning disjointed provisions***

Previously, section RP 19(3) referred to section RP 19(2). However, in 2011, section RP 19(3) was amended to prevent an unintended ability to use tax pooling funds to eliminate imputation account debit closing balances. However, section RP 19(2) was not amended at that time, which has resulted in the sections not making sense when read together. The proposed amendment would restore the link by amending section RP19(3) to make it clear that purchased tax pooling funds can be transferred with an effective date that is on or after the first day of the relevant income year.

### ***Including look-through companies in the definition of "small-business person"***

Section RC 40 of the ITA contains some definitions for the EPD, including that it applies to a person who is self-employed or a partner in a partnership. This section was written before LTCs were introduced and was not updated following their creation.

In an LTC, the revenue flows through to the owners as if it was their own income (much like a partnership). As a partnership is included within the definition of a small-business person, it follows that an LTC should also be included. The proposed amendment to section RC 40 to include LTCs for a small-business person is in line with the current treatment of partnership income in the hands of an individual.

## **CUSTODIAL INSTITUTIONS – DEFINITION OF END INVESTOR**

---

*(Clauses 117 and 140)*

### **Summary of proposed amendment**

The proposed amendment to the definition of an “end investor” would ensure that a custodial institution whose New Zealand operation is a fixed establishment of a non-resident entity could access the investment income withholding and reporting obligations as intended.

### **Application date**

The proposed amendment would apply from 1 April 2020 for the 2020–21 and later income years.

### **Key features**

The proposed amendment would change the definition of “end investor” in section RE 10C(7) of the Income Tax Act 2007 and section 25MB(8) of the Tax Administration Act 1994 to include branches in New Zealand of non-resident custodial institutions. This would allow these branches to take advantage of the relaxed reporting and withholding obligations for custodial institutions.

### **Background**

Custodial institutions act as a conduit between the payer of investment income and the ultimate owner of that income. New rules to clarify the investment income withholding and reporting obligations imposed on custodial institutions were introduced by the Taxation (KiwiSaver, Student Loans, and Remedial Matters) Act 2020 with effect from 1 April 2020. The rules provide for some relaxations of the strict requirements of the general withholding and reporting rules.

The general rules place the obligation for withholding tax and reporting to Inland Revenue on the custodial institution that pays or transfers investment income to an end investor. An end investor can be resident or non-resident and may be a person or an entity. Where the income passes to a non-resident custodial institution, these reporting and withholding obligations are relaxed.

Some custodial institutions operate their New Zealand business by way of a fixed establishment in New Zealand. It is intended that, in all cases, the New Zealand business should withhold tax and report to Inland Revenue when it pays or transfers investment income to an end investor. However, the New Zealand fixed establishment is not a separate legal person from the overseas parent. As fixed establishments are currently excluded from the definition of an end investor, those custodial institutions that use this business model are unable to access the relaxations of the rules available to others. This outcome is contrary to the policy intent. The proposed amendments are intended to address this.

## CORPORATE SPIN-OUTS AND SHAREHOLDING CONTINUITY

---

*(Clause 129)*

### **Summary of proposed amendment**

The proposed amendment would prevent a spun-out company from breaching shareholder continuity requirements due to a corporate spin-out when there has been no change in ultimate ownership.

### **Application date**

The proposed amendment would apply from the date the Bill was introduced.

### **Key features**

Proposed section YC 13(1B) would treat the notional single person that holds an interest in a spun-out company after a spin-out as holding the original parent's interest in the spun-out company before the spin-out.

### **Background**

For the purposes of section YC 13, a spin-out involves the shareholders in a parent company (the original parent) acquiring the shares in a subsidiary of the original parent (the spun-out company). Section YC 13 currently addresses shareholding continuity problems for subsidiaries of a spun-out company that are caused by a spin-out.

However, under current law, tax losses and credits of a spun-out company itself can still be lost as a result of a spin-out even though, from an economic viewpoint, no change in ownership occurs because the company retains the same ultimate shareholders.

The proposed amendment would address this specific shareholding continuity problem. However, it does not address all problems caused by spin-outs, as a broader set of rules regarding spin-outs would be complex and would have to undergo the usual tax policy processes. This is not possible within current timeframes.

### **Detailed analysis**

#### ***Clarification of form of spin-out***

Section YC 13 applies to a form of spin-out described in section YC 13(1). Proposed section YC 13(1)(db) is intended to clarify that, in this form of spin-out, a notional single person would hold a voting interest or market value interest in the spun-out company after the spin-out.

#### ***Rule for ownership of a spun-out company***

Proposed new section YC 13(1B) is intended to address shareholding continuity problems for a spun-out company. The proposed new provision would address these problems in a



similar way to how section YC 13(2) currently addresses the shareholding continuity problems for a subsidiary of a spun-out company.

Under the proposed new provision, the notional single person that holds an interest in the spun-out company after a spin-out would be treated as holding the original parent's interest in the spun-out company before the spin-out. However, this treatment would only apply to the extent a group of persons exists who hold common interests in the original parent and the spun-out company immediately after the spin-out, calculated on the assumption that the only interests in those companies are those held by a notional single person.

## **SHARE-FOR-SHARE EXCHANGES AND AVAILABLE CAPITAL DISTRIBUTION AMOUNT**

---

*(Clause 53(1))*

### **Summary of proposed amendment**

The proposed changes would amend the calculation of the available capital distribution amount (ACDA) arising when a company (Acquirer) disposes of shares in another company (Target) acquired in a share-for-share exchange to a non-associated party. ACDA would be increased by the amount that was excluded from Acquirer's available subscribed capital (ASC) by section CD 43(10) when those shares were acquired. This would allow a distribution of the same amount to not be treated as a taxable dividend upon the liquidation of Acquirer.

### **Application date**

The proposed amendment would apply to distributions upon the liquidation of an Acquirer from the date of enactment. This may include distributions arising from the proceeds of the sale of shares in Target before this date.

### **Key features**

A component of the ACDA calculation is capital gains. Capital gains arise under section CD 44(7) and include disposing of capital property for more than the cost of the property to the company (subsection (a)) and a capital gain distributed by a subsidiary upon its liquidation (subsection (c)).

Proposed new section CD 44(7B) would provide for an additional capital gain amount equal to the amount that was excluded from Acquirer's ASC under current section CD 43(10). This amount would arise when Acquirer sells some or all of its shares in Target to a third party.

### **Background**

A share-for-share exchange is when the shareholders of a company (Target) transfer ownership of Target to another company (Acquirer) in exchange for shares in Acquirer. Two common applications of a share-for-share exchange are: internal restructuring to insert a holding company; and mergers/acquisitions where Acquirer purchases Target from a third party and issues shares in itself to Target's former shareholders rather than paying cash.

Generally, when property is contributed to Acquirer in exchange for shares, Acquirer's ASC is increased by the value of the property at the time of the contribution. This amount can be distributed tax free on a share repurchase or liquidation of the company.

However, if the property is shares in another company (Target), this is undesirable. For example, suppose Target is worth \$500, and it has ASC of \$100 and retained earnings of \$400. If, by simply contributing Target to Acquirer, the contribution of Target's shares to Acquirer increased Acquirer's ASC by \$500, the \$400 of retained earnings would be able to

be distributed tax free (first as an exempt intercorporate dividend from Target to Acquirer, then as a liquidating distribution of ASC or share repurchase by Acquirer to its shareholders).

To prevent this outcome, sections CD 43(9) and (10) limit the ASC of the shares issued by Acquirer to the ASC of the contributed shares in Target (\$100 in the above example). This is known as the share-for-share ASC limitation.

However, this response creates a flow-on problem if Acquirer sells Target and is later liquidated. The problem is easiest explained as a sequence of transactions:

1. The first transaction is a share-for-share exchange, where Acquirer acquires shares in Target from the Target shareholders in exchange for the issue of shares in Acquirer to the Target shareholders. The ASC of the issued shares is limited to the ASC of the Target shares under sections CD 43(9) and (10). The problem arises only if the ASC of the Target shares is less than their value (which it usually is).
2. The second transaction is the sale of Target by Acquirer. The gain or loss from this sale will be measured by comparing the sale price with the value of the Target shares when they were acquired by Acquirer in the share-for-share exchange.
3. The third transaction is the liquidation of Acquirer. This is the point at which the problem arises. Because of the ASC limitation referred to in step 1, the Acquirer shareholders are taxed on the liquidating distribution to the extent that it is funded out of the sale of Target and the sale proceeds recover the cost of the Target shares in excess of Target's ASC. This means the Acquirer shareholders are taxed more heavily on the liquidating distribution than if the share-for-share exchange in step 1 had not occurred, in which case the Target shareholders would have either liquidated or sold Target directly.

This is explained further in example 29.

**Example 29: Problem under current law**

Acquirer has \$500 retained earnings and \$500 cash. Target has \$300 ASC and \$200 capital gain. If Acquirer was liquidated, Shareholder 1 would receive a \$500 taxable dividend. If Target was liquidated, the \$500 distributed to Shareholder 2 would be \$300 ASC and \$200 ACDA, so there would not be a taxable dividend.

Instead, Target is acquired in a share-for-share exchange with Shareholder 2 on capital account. Target is subsequently sold to a third party for \$500. Acquirer is liquidated immediately thereafter.

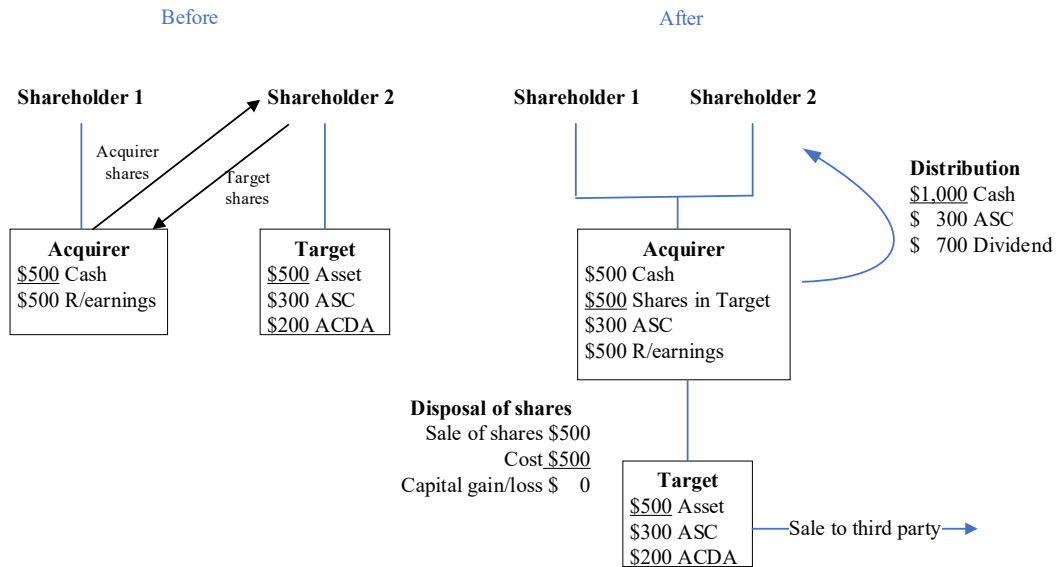

Acquirer ACDA is \$0. The \$1,000 distributed would be \$300 ASC and \$700 taxable dividend. Taxable dividends are \$200 higher than if the share-for-share exchange had not occurred.

**Detailed analysis**

When a shareholder is paid an amount in relation to a share on liquidation of a company, section CD 26 provides that the amount paid is a taxable dividend only to the extent to which it is more than the ASC per share calculated under the ordering rule and the ACDA per share.

The ACDA per share is calculated by applying the formula in section CD 44(1):

$$(\text{receipt} - \text{ASC per share}) \times (\text{capital gains} + (\text{capital property distributed} - \text{cost}) - \text{capital losses}) \div (\text{total receipts} - \text{total ASC})$$

For the purposes of this formula, sections CD 44(7)(a) and CD 44(9) provide that “capital gains” and “capital losses” include a gain or loss on disposal of capital property.

Although the ASC limitation in sections CD 43(9) and (10) reduces the additional ASC to Acquirer from the share-for-share exchange, it does not impact the cost of the Target shares, which will be equal to their market value. This means if Acquirer sells Target, its capital gain will only be equal to the increase in share value since the share-for-share exchange. This effectively means Acquirer’s shareholders will be taxed when the proceeds from the sale of Target shares are distributed, even though this would partially be a recovery of the cost.

While removing the ASC limitation would allow these amounts to be distributed tax free to Acquirer’s shareholders, it would also allow these amounts to be distributed tax free without

selling Target or liquidating Acquirer. This would place Acquirer's shareholders in a better position than if the share-for-share exchange had not occurred.

Instead, the proposed amendment would create an additional capital gain that would flow through to the ACDA formula shown above. This would allow any gains that could have been derived by Target's former shareholders by selling shares in Target to instead be distributed tax free as ACDA to Acquirer's shareholders.<sup>16</sup> This capital gain would arise only when all of the following requirements are met:

- target has been acquired by Acquirer in a share-for-share exchange that meets the requirements of section CD 43(9)
- acquirer's ASC uplift has been limited by section CD 43(10), and
- acquirer has subsequently sold shares in Target to a third party.

---

<sup>16</sup> This may include Target's former shareholders unless they have sold their shares in Acquirer after the share-for-share exchange but before Acquirer is liquidated.

## **DEBT REMISSION WITHIN AN ECONOMIC GROUP**

---

*(Clauses 50, 52, 53(2)–(3), 65, 80, 85, and 127(11), 127(14) and 127(15))*

### **Summary of proposed amendment**

The proposed remedial amendments would clarify the related party debt remission rule in section EW 46C and other associated provisions.

### **Application date**

The first proposed amendment (relating to terminology) would apply for a person for the 2008–09 and later income years, except for an income year before the 2015–16 income year for which the person takes a tax position in a return of income that is inconsistent with the amendments.

The other two amendments would apply from the date of enactment.

### **Key features**

The proposed amendments would clarify the rules for debt remission within economic groups by:

- clarifying that the related party debt remission rule applies to any type of remission, not only forgiveness
- providing an available subscribed capital (ASC) increase to a resident company within a wholly-owned group of companies where a shareholder remits a debt owed by the company (without requiring the company to capitalise the debt), and
- applying the related party debt remission rule to the remission of debt owed by a New Zealand branch of a non-resident company to a member of the same wholly-owned group.

### **Background**

Generally, when debt is remitted the debtor derives taxable income to reflect that they are better off by the amount of debt they no longer have to pay. An exception to this is the related party debt remission rule. This rule provides that, in some circumstances, debt forgiven within an economic group is not income for the person who owes the debt (the debtor). This leads to the correct result, as bad debts are not deductible to an associated party creditor. There is therefore no income for the debtor and no deduction for the creditor, which reflects that net worth is unchanged from the remission when considered on a group basis.

Three proposed remedial amendments would ensure that the related party debt remission rule operates as intended.

## **Detailed analysis**

### ***Use of terminology***

The language in the debt remission rule is centred around the word “forgiveness”. However, the rule is commonly understood to apply to all types of debt remission (for example, when debt is not forgiven but is remitted by a court order or due to the passing of time). To align with current practice, proposed amendments to section EW 46C would replace references to “forgiveness” (and its derivatives) with “remission” (and its derivatives).

### ***Available subscribed capital***

Where a shareholder of a company remits a debt owed by the company, an increase in available subscribed capital (ASC) is permitted to recognise that the remission of a loan is in substance a capital contribution to the company. Currently, a resident company must capitalise the debt, but a non-resident is not required to do so in the same circumstances. A proposed amendment to section CD 43(6B) would allow the resident company to obtain an ASC increase where debt is remitted even when no shares are issued.

### ***Remission of debt owed by New Zealand branches of non-residents***

The related party debt remission rule only applies in limited circumstances to debt owed by branches of non-resident companies. Branches located in New Zealand are treated very similarly to New Zealand resident subsidiaries for debts owing. Where a New Zealand branch owes money to an associate that is a New Zealand resident or a non-resident with a New Zealand branch, an asymmetrical outcome arises because no deduction is provided to the creditor, but debt remission income is recognised for the New Zealand branch.

Proposed amendments to section EW 46C(1)(a) would extend the debt remission rule to a New Zealand “fixed establishment”, provided it meets the other requirements in the debt remission rule that apply to New Zealand residents. However, this would be limited to apply only where the creditor does not receive a deduction on the remission of the debt (in New Zealand or offshore).

## **EMPLOYER SUPERANNUATION CONTRIBUTION TAX ON CONTRIBUTIONS FOR PAST EMPLOYEES**

---

*(Clause 115)*

### **Summary of proposed amendment**

The proposed amendment would reduce the employer superannuation contribution tax (ESCT) rate on contributions for past employees from 39% to 33%.

### **Application date**

The proposed amendment would apply from 1 April 2022.

### **Background**

In general, ESCT rates are designed to match an individual's marginal income tax rate. However, a couple of exceptions exist where it is not practical to do so. While it is not common, some employers continue to make contributions after an individual leaves their employment. In these circumstances, a flat rate applies because an employer will not have up-to-date information for past employees to enable them to match an individual's rate.

At the time the 39% personal income tax rate was introduced, a decision was made to increase the rate of tax on employer superannuation contributions made for past employees from 33% to 39%. However, the 39% rate results in over-taxation in nearly all past employee cases. Reverting to a 33% rate would be more accurate and poses minimal integrity risk.

Some employers who make contributions to defined benefit schemes elect to pay a flat rate of ESCT because they wish to avoid the administrative costs of allocating the contributions to specific employees. Employers would continue to be able to elect a flat rate of 39% when contributions are to a defined benefit scheme. This rate will remain 39% because use of the rate is not mandatory. Employers retain the ability to attribute contributions to defined benefit schemes to specific individuals using the usual ESCT rates.



## DEFINITION OF “DECOMMISSIONING” IN THE PETROLEUM MINING REGIME

---

*(Clause 127(4))*

### **Summary of proposed amendment**

The proposed amendments would modify the definition of “decommissioning” in the petroleum mining tax rules. The intention is to ensure that refundable credit claims for decommissioning expenditure only relate to expenditure on wells that have both contributed to further petroleum production and been permanently plugged and abandoned.

### **Application date**

The proposed amendment would apply from the date of enactment.

### **Key features**

Proposed remedial amendments to the definition of “decommissioning”:

- Exploratory wells that are geologically contiguous with a commercial well but that have not contributed to the commercial production of petroleum would be removed from the definition of “decommissioning”.
- For clarification, the term “plugging and abandoning” used within the definition of “decommissioning” would be amended to “permanently plugging and abandoning”.

### **Detailed analysis**

Since 2018, petroleum miners have been allowed a refundable credit for qualifying expenditure on decommissioning petroleum assets. Part of the definition of “decommissioning” in the Income Tax Act 2007 refers to plugging and abandoning certain types of wells, including production wells and other wells used in the commercial production of petroleum.

#### ***Narrowing the scope of eligible wells***

Paragraph (b)(ii) in the definition of “decommissioning” in section YA 1 extends the scope to exploratory wells that are plugged and abandoned in a permit area together with a commercial well geologically contiguous with the exploratory well. This was intended to cover a situation where a petroleum miner delays plugging and abandoning an exploratory well in case it is used in future for water or gas injection (to extend the life of a geologically contiguous production well). The petroleum miner may be allowed a refundable credit if they decommission the exploratory well and the production well together as part of an arrangement.

An unintended consequence of this paragraph in the decommissioning definition is that it is possible for expenditure on plugging and abandoning an exploratory well to be eligible for a refundable credit even if there was never an intention that the well might be used in the production process. This is exacerbated by the fact that the phrase “geologically contiguous”

is likely to be a broader term than what was contemplated at the time the definition was introduced. The proposed amendment would repeal this paragraph within the definition to narrow the scope of eligible wells to what was originally intended. Expenditure on decommissioning production wells and other wells used in the commercial production of petroleum would continue to be eligible for a refundable credit through the other existing parts of the definition.

***Clarifying that plugging and abandoning means doing so permanently***

A well can be suspended so that it does not create any environmental risks while a decision is made on what to do with it in future. However, the petroleum decommissioning definition only refers to the plugging and abandonment of wells and does not explicitly differentiate between a well that has been suspended, or plugged and abandoned temporarily, and a well that has been permanently plugged and abandoned.

The proposed amendment would ensure that the definition refers to permanently plugging and abandoning wells. This would clarify that temporarily plugging and abandoning a well does not fall within the definition and would prevent petroleum miners from being allowed a refundable credit for expenditure on temporarily plugging and abandoning a well.

## **ABILITY TO REFUND ANCILLARY TAXES**

---

*(Clauses 121 and 122)*

### **Summary of proposed amendment**

The proposed amendments would deem the filing of an ancillary tax return to be an assessment for the purposes of sections RM 2 and RM 4 of the Income Tax Act 2007. This would ensure that amounts of overpaid ancillary tax can be refunded.

### **Application date**

The proposed amendments would apply in relation to a return for an amount of an ancillary tax for a period regardless of whether the return was or is provided before, on or after the date of enactment.

### **Detailed analysis**

Under current law, the filing of an ancillary tax return is not an assessment. The refund rules require an assessment before an amount of overpaid tax can be refunded. This means that, in most cases, no legislative ability to refund ancillary taxes currently exists. This is contrary to the policy intent of the refund rules.

The proposed amendments would deem the filing of an ancillary tax return to be an assessment for sections RM 2 and RM 4 so that amounts of overpaid ancillary tax could be refunded.

## **AMENDING MEMORANDUM ACCOUNTS WHEN MAKING TRANSFER FROM PREVIOUS YEARS**

---

*(Clauses 90, 98–107, 110, and 123)*

### **Summary of proposed amendment**

The proposed amendments would permit imputation credit account (ICA) entries that result from a transfer of tax from a previous period to be made on the date that the taxpayer requests the transfer, rather than the effective date chosen by the taxpayer.

This is as long as:

- the ICA of the transferee is in credit on 31 March of the imputation year in which the effective date arises, and
- the ICA of the transferor on 31 March of the imputation year in which the effective date arises was in credit by at least the amount of the transfer and any other transfers made during that imputation year.

This change also extends to Māori Authority Credit Accounts (MACAs).

Transfers made before the end of an income year would continue to be made in the current year.

### **Application date**

The proposed amendments would apply from the date of enactment.

### **Key features**

The proposed amendments would permit ICA entries resulting from a transfer of tax from a previous period to be made on the date that the taxpayer requests the transfer, rather than the effective date chosen by the taxpayer.

This is provided that on 31 March of the imputation year in which the effective date arises:

- the ICA of the transferee is in credit, and
- the ICA of the transferor was in credit by at least the amount of the transfer and any other transfers made during that imputation year.

This change would also extend to Māori Authority Credit Accounts (MACAs).

Transfers made before the end of an income year would continue to be made in the current year.

### **Background**

An issue has been raised that the current practice of taxpayers and Inland Revenue accounting for ICA/MACA entries may not be in line with a strict interpretation of the relevant legislation when making transfers between tax types or taxpayers. Under a strict

interpretation of the law, taxpayers who transfer tax between tax types or taxpayers must request the Commissioner make amendments to ICAs/MACAs that have already been included as part of a tax return filed with Inland Revenue, where those tax transfers occur at a date outside of the tax year in which the transfer is requested.

However, in practice, entries to ICAs/MACAs from previous years are not amended to reflect a transfer of tax from a previous period to a future period. Rather, entries reflecting the transfer are included in the ICA of the year of transfer.

The interpretation of current law can increase compliance and administration costs for both taxpayers and Inland Revenue for little to no gain where the respective accounts are in credit. It is preferable that the legislation be amended to allow transfers to be dealt with in the year of transfer, subject to certain requirements.

### **Detailed analysis**

Section OB 4(4) of the Income Tax Act 2007 (ITA) sets out the credit dates for different types of debits and credits to a company's ICA. An amendment proposes to insert paragraph (c) to this section for amounts transferred in a tax year from another period under sections 173L and 173M of the Tax Administration Act 1994 (TAA) and section RC 32(5)(b) of the ITA.

Under proposed subparagraph (i), the credit date of these amounts would be the day on which the taxpayer requests the transfer, provided that the credit in the ICA equals or exceeds the amount of all transfers from that account requested in the tax year, and that the ICA to which the transfer is made is also in credit.

If these requirements are not met, proposed subparagraph (ii) would clarify that the credit date would instead be the date of transfer, as defined in sections 173L and 173M of the TAA or section RC 32(5)(b) of the ITA.

Proposed amendments to table O1 reflect the additions to section OB 4(4). More specifically, row 2 would be replaced with rows 2, 2B and 2C. Rows 2B and 2C would indicate the different credit dates as set out in sections OB 4(4)(c)(i) and OB 4(4)(c)(ii) respectively.

Corresponding amendments are also proposed for section OB 32 and table O2, which pertain to the debit side of the ICA transfer.

These proposed changes would also apply to debits and credits in MACAs (sections OK 2, OK 3, OK 11, OK 12 and tables O17 and O18).

Transfers made under sections 173L and 173M of the TAA or section RC 32(5)(b) of the ITA during an income year would continue to use the dates prescribed by those sections.



---

## Other remedials

---





## **EXTENDING USE OF MONEY INTEREST RELIEF DURING COVID-19**

---

*(Clause 169)*

### **Summary of proposed amendment**

The proposed amendment would modify the scheme that allows for an extension of use of money interest (UOMI) relief for taxpayers affected by COVID-19. The proposed changes would allow the scheme to be extended retrospectively and for a specific group of taxpayers described in an Order in Council. The proposed changes would also include a time limit of 36 months for extensions that could be set within an Order in Council.

### **Application date**

The proposed amendments would apply from 25 March 2022.

### **Key features**

The proposed amendments to the provisions for extending UOMI relief for taxpayers affected by COVID-19 would:

- allow an Order in Council made under the scheme to describe a specific group of taxpayers the Order in Council applies to
- change the time limit within which an Order in Council must be made to allow the scheme to be extended retrospectively, and
- limit the time limit that can be set by an Order in Council to 36 months.

### **Detailed analysis**

Section 183ABAB of the Tax Administration Act 1994 currently allows for the remission of UOMI for taxpayers affected by COVID-19, subject to meeting the criteria outlined in the section. Sections 183ABAB(4) and (5) allow the scheme to be extended by an Order in Council made on the recommendation of the Minister of Revenue.

The proposed amendments would allow for an Order in Council made under either of these sections to specify a group of taxpayers the Order in Council applies to. This would enable UOMI relief to be extended for a specific group of taxpayers if that is preferred, rather than having a general extension for all taxpayers. This would mirror the equivalent provisions in section 183ABA, under which UOMI can be remitted for a specific group of taxpayers for emergency events.

Given the timing difference between the current expiry date of the scheme of 24 March 2022 and the potential date of enactment of this Bill, it is also proposed that an Order in Council to extend the scheme could be made within six months of the scheme's expiry date. This would allow the scheme to be extended retrospectively, which would ensure that an Order in Council made to extend the scheme could take account of these proposed amendments.

The proposed amendments would also include a 36-month limit on the length of the extension that could be set by an Order in Council. This would not limit the ability for such an Order in Council to be renewed.

## **INVESTMENT INCOME INFORMATION – ALIGNING FILING AND PAYMENT DATE FOR SIX-MONTHLY PAYERS OF INVESTMENT INCOME**

---

*(Clause 141)*

### **Summary of proposed amendment**

The proposed amendment would align the investment income information filing dates for those payers of investment income who meet certain de minimis criteria with their six-monthly payment date.

### **Application date**

The proposed amendment would apply for the 2022–23 and later income years.

### **Key features**

The proposed amendment to the filing options under subpart 3E of the Tax Administration Act 1994 (TAA) would allow payers who meet the criteria set out in sections RE 21 or RF 13(2) of the Income Tax Act 2007 (ITA), or section 89KA of the Stamp and Cheque Duties Act 1971 (SCDA), to file their investment income information six-monthly. This would align with the payment date.

### **Background**

Before 1 April 2020, the legislation contained a de minimis option that allowed payers of investment income who met certain criteria to file and pay resident withholding tax (RWT), non-resident withholding tax (NRWT) and the approved issuer levy (AIL) six-monthly.

Under the post 1 April 2020 investment income reporting rules, such payers still have the six-monthly payment option but do not have a de minimis option of filing six-monthly.

This places an undue compliance burden on payers who must now meet the requirements under the ITA, or the SCDA, to provide investment income information monthly. Reinstating a de minimis option by amending the investment income reporting rules in the TAA would allow payers that meet the criteria to file and pay six-monthly, as was the case before 1 April 2020. This would lower their compliance costs.

A variation has been granted for the 2020–21 and 2021–22 income years to allow a six-monthly filing option consistent with the rules that applied before 1 April 2020. The proposed amendment would replace that variation on a permanent basis.

## NON-ACTIVE ESTATES RETURN FILING

---

*(Clause 143)*

### **Summary of proposed amendment**

The Tax Administration Act 1994 (TAA) provides an exclusion for trustees of non-active trusts from their tax return filing obligations under section 43B. However, this section does not include non-active estates. This gives rise to a compliance cost that could be saved if the estate were able to apply for an exclusion under section 43B.

The proposed amendment would amend section 43B to extend the non-filing provision to include non-active estates.

### **Application date**

This amendment would apply from 1 April 2022.

### **Background**

Executors and administrators of estates have an obligation to file income tax returns under section 43(1) of the TAA. This obligation means estates that do not derive income (non-active estates) are still required to file income tax returns. This can cause issues for executors and administrators of estates who may be obligated to file income tax returns for many years despite deriving little to no income.

The TAA provides an exclusion for trustees of non-active trusts from their tax return filing obligations under section 43B. However, this section does not include non-active estates. This is because an estate is not a “trust” in the ordinary meaning of the word.

While conflicting advice and interpretations of the section have been given over the years, causing confusion for executors and administrators, the current position is that estates cannot apply under section 43B (although testamentary trusts can generally utilise section 43B, as can executors and administrators that have reached the point of distribution where the property is to be held on trust for beneficiaries).

The obligation to file gives rise to a compliance cost that could be saved if the estate were able to apply for an exclusion under section 43B of the TAA.

### **Detailed analysis**

The proposed amendment would allow executors and administrators of non-active estates to apply for an exemption from filing where the non-active estate meets the requirements in section 43B(2). Executors and administrators of non-active estates that qualify would then be able to file an IR633 non-active declaration to exempt them from having to file income tax returns.

## **REPEAL OF INFORMATION SHARING CLAUSES FOR THE ACC AND THE REGISTRAR OF COMPANIES BY AN ORDER IN COUNCIL**

---

*(Clauses 173(2) and 173(3))*

### **Summary of proposed amendment**

The proposed amendment would repeal clauses 36, 41 and 42 of schedule 7 of the Tax Administration Act 1994 (TAA) on a date set by an Order in Council.

### **Application date**

The proposed amendments would apply from a date set by an Order in Council.

### **Background**

Inland Revenue is currently developing Approved Information Sharing Agreements (AISAs) with the Accident Compensation Corporation (ACC) and the Ministry of Business, Innovation, and Employment (MBIE). These two AISAs will replace existing information-sharing provisions in the TAA.

The Privacy Act 2020 prevents two provisions for sharing the same information from being in place at the same time. This means that the relevant information-sharing provisions of the TAA would need to be repealed as the two AISAs come into force.

As we cannot determine exactly when the new AISAs would take effect, the proposed amendment would repeal the relevant information-sharing provisions of the TAA on a date set by an Order in Council.

## COMMISSIONER'S REMEDIAL POWERS – DISPUTABLE DECISIONS

---

*(Clause 155(1))*

### **Summary of proposed amendment**

The proposed amendment would clarify that the disputes and challenge processes in the Tax Administration Act 1994 (TAA) do not apply to decisions of the Commissioner using the remedial powers in that Act.

### **Application date**

The proposed amendment would apply from the date of enactment.

### **Key features**

The proposed amendment would clarify that the disputes and challenge procedures of the TAA do not apply for the purposes of resolving disagreements with the Commissioner about the application of the discretionary remedial powers.

### **Background**

As a general rule, discretionary administrative matters left to the Commissioner under a provision of the Inland Revenue Acts should not be subject to the disputes and challenge procedures of the TAA. This reflects the fact that the purpose of the disputes process is to ensure that an assessment is as correct as practicable and to deal with any disputes over tax liability fairly, and efficiently.

Sections 6C to 6G were inserted into the TAA in 2019. These sections contain remedial powers, including discretionary regulation-making powers that can be exercised in limited circumstances. These powers enable Orders in Council to be made on the recommendation of the Minister of Revenue to modify the application of tax laws. They also provide for exemptions to be granted by the Commissioner to exempt a person from provisions of tax laws where those laws contain minor errors or are otherwise unable to be interpreted as giving effect to intended policy outcomes. Generally, a six-week period of public consultation is required on any proposed Order in Council or exemption before it comes into force. This can be shortened or dispensed with if it is considered that a case of urgency exists.

For the avoidance of doubt, the proposed amendment would clarify that a person cannot initiate the disputes and challenge procedures of the TAA for decisions made by the Commissioner to grant (or not grant) an exemption, or to shorten or dispense with the period of public consultation for proposed exemptions if the Commissioner considers a case of urgency exists. This would recognise that more appropriate mechanisms are in place for resolving issues about regulation-making powers, such as judicial review and the Regulations Review Committee.

## **Detailed analysis**

The proposed amendment to section 138E(1)(e)(iv) (Rights of challenge not conferred) of the TAA would include a reference to sections 6E (Exemptions granted by Commissioner) and 6F (Consultation on proposed modifications and exemptions).

This would mean a person could not commence challenge proceedings against decisions made by the Commissioner under either section 6E or section 6F. It would also follow that the disputes process in the TAA would not apply to decisions made by the Commissioner under either of those provisions. This is because the disputes process cannot be initiated for issues for which a person has no right of challenge under the TAA.

## **CHALLENGE NOTICES – WHETHER REQUIRED AFTER AMENDED ASSESSMENT ISSUED**

---

*(Clause 148)*

### **Summary of proposed amendment**

The proposed amendment would clarify that the Commissioner is not required to issue a challenge notice where, following completion of the disputes process in a taxpayer-initiated dispute, an assessment is issued that reflects some but not all of the adjustments proposed by the taxpayer.

### **Application date**

The proposed amendment would apply from the date of enactment.

### **Key features**

The proposed amendment would clarify that the Commissioner is not required to issue a challenge notice following completion of a taxpayer-initiated dispute where the Commissioner issues an amended assessment, and the taxpayer has challenge rights pursuant to the amended assessment.

### **Background**

In taxpayer-initiated disputes, the Commissioner is required to issue a challenge notice to mark the end of the disputes process under the Tax Administration Act 1994 (TAA).

The challenge notice then forms the basis for the taxpayer to commence proceedings with either the High Court or the Taxation Review Authority.

The issue is that it is unclear whether the Commissioner needs to issue a challenge notice in circumstances where, at the end of the disputes process, the Commissioner issues an amended assessment that reflects some, but not all, of the taxpayer's proposed adjustments. In such circumstances, if the Commissioner were to issue a challenge notice, there would seem to be two bases on which a taxpayer could commence challenge proceedings:

- the first is where an amended assessment has been issued: section 138B(2) of the TAA, and
- the second is where a challenge notice has been issued: section 138B(3) of the TAA.

It is not intended that two separate bases exist for a taxpayer to commence challenge proceedings with a hearing authority. Further, the Commissioner should not be required to issue a challenge notice to mark the end of the disputes process where an amended assessment is issued. This is because the amended assessment should form the basis of any challenge proceedings.

The proposed amendment would clarify that a challenge notice would not be required to be issued where, following completion of the disputes process, an amended assessment was



issued that reflected some, but not all, of the adjustments proposed by the taxpayer, and the taxpayer could initiate challenge proceedings on the basis of the amended assessment.

**Example 30**

A taxpayer issues the Commissioner with a notice of proposed adjustment (NOPA) that raises two different issues. The Commissioner concedes the first issue but, following completion of the disputes process, does not concede the second issue. The Commissioner then issues an amended assessment that reflects an assessment the Commissioner considers to be correct, taking into account the effect of the first issue raised in the taxpayer's NOPA but ignoring the second issue.

In example 30, the taxpayer could commence challenge proceedings in accordance with the procedure outlined in section 138B(2) of the TAA – that is, by filing proceedings in accordance with the Taxation Review Authority Regulations 1994 or the High Court Rules 2016 within the response period following the issue of the amended notice of assessment.

## **REMOVING FAX AS A MODE OF COMMUNICATION**

---

*(Clauses 41, 128, 136, 137, 138, 199, and 200)*

### **Summary of proposed amendment**

Given the increasingly digital way we work and the inability for our technology partners to continue to support faxes, Inland Revenue is no longer able to accept faxes.

The proposed amendments would remove fax as an approved method of communication between a person and the Commissioner in the Inland Revenue Acts.

### **Application date**

The proposed amendments would apply to the Goods and Services Tax Act 1985 for taxable periods starting on or after the date of enactment.

The proposed amendments would apply for other Inland Revenue Acts from the date of enactment.

### **Detailed analysis**

Currently, faxes are an approved method of communication (along with personal delivery, post, and electronic means) between a person and the Commissioner in the Inland Revenue Acts. However, as faxes will no longer be supported by 31 August 2021, the legislation should be amended to reflect this. The proposed amendment would also clarify the position for persons communicating with the Commissioner.

The proposed amendment would remove all references to fax in the Inland Revenue Acts. The proposed amendment would amend sections 14, 14F and 14G of the Tax Administration Act 1994, section YA 4 of the Income Tax Act 2007, section 75B of the Goods and Services Act 1985, and sections 211 and 212 of the Student Loan Scheme Act 2011.

## **R&D TAX INCENTIVE – EXTENSION OF DUE DATES**

---

*(Clauses 142 and 145)*

### **Summary of proposed amendment**

The proposed amendments would extend certain due dates for years one and two (2019–20 and 2020–21) of the R&D Tax Incentive (RDTI) to 31 August 2021.

### **Application date**

The proposed amendments would apply from 1 April 2019 for year one supplementary returns and from 1 April 2020 for year two approvals.

### **Key features**

The proposed amendments to the Tax Administration Act 1994 would extend RDTI due dates to 31 August 2021 for:

- year one (2019–20) income year supplementary returns (proposed new section 33F), and
- year two (2020–21) income year general approvals and criteria and methodologies approvals (proposed new section 68CF).

If a taxpayer has a late balance date that results in their due date being later than 31 August 2021, then this later due date would remain. Supplementary returns, general approvals and criteria methodologies approvals submitted after pre-amendment due dates, but before 1 September 2021, would be processed by Inland Revenue once the Bill has been enacted.

## **R&D TAX INCENTIVE – TAX YEAR CUT-OFF FOR CLAIMING SUPPORTING ACTIVITIES**

---

*(Clauses 92 and 144)*

### **Summary of proposed amendment**

The proposed amendment would permit supporting activity expenditure that arises one year before or one year after a relevant core R&D activity to be eligible for the R&D Tax Incentive (RDTI).

### **Application date**

The proposed amendments would apply for the 2020–21 and later income years, and would permit supporting activity expenditure incurred from the 2019–20 and later income years to be claimed.

### **Key features**

The proposed amendments would:

- include supporting activity that occurs up to one year before and one year after a relevant core activity in the definition of “eligible R&D expenditure” in section LY 5 of the Income Tax Act 2007 (ITA) so that it would be included in the calculation of a person’s tax credit under section LY 4, and
- allow for the variation of a general approval under section 68CB of the Tax Administration Act 1994 (TAA) to give businesses time to seek approval for supporting activities occurring the year before or after the core activity.

### **Detailed analysis**

#### ***Supporting activities outside the year the core activity is performed***

Supporting activity expenditure is intended to only be eligible for the RDTI where a corresponding core activity has commenced (as this means there is R&D activity). Section LY 3 of the ITA gives effect to this policy by requiring a core activity to exist in the income year for any credit to be claimed.

However, using the concept of an income year unintentionally resulted in some arbitrary exclusions from eligibility where the expenditure was incurred outside the income year in which the core activity occurred. For example, expenditure incurred on a pre-commencement supporting activity in March 2021 is currently ineligible if the core activity does not start until a month later in April 2021. If both happened in April 2021, then all expenditure would be claimable. A similar scenario occurs if expenditure for a supporting activity relating to the end of an R&D activity is incurred in the tax year after that core activity concludes.

The proposed amendment would amend the definition of eligible R&D expenditure in section LY 5 by inserting section LY 5(1)(ab). This paragraph would include expenditure

incurred on a supporting activity occurring up to one year before or one year after the relevant core activity commences or ceases, respectively, in the calculation of a person's tax credit in section LY 4. The effect would be that pre- and post-core supporting activity expenditure or loss would be claimable in the year of the core activity. For example, if pre-core supporting activity expenditure arose in the 2019–20 income year, it could be claimed in the 2020–21 supplementary return if there was a core activity in that year. For post-core supporting activity, the expenditure would be claimed in the supplementary return for the year prior, where the core activity occurred. For example, post-core supporting activity in 2022–23 could be claimed in the 2021–22 supplementary return. This might require re-opening the assessment for that year.

As the supporting activity would be claimed in the income year the core activity occurs in, it would count towards the various caps for that year, for example, the \$120 million total cap on expenditure in section LY 4(3)(i).

### ***Variation powers***

R&D activities (core and supporting) are only eligible for the tax credit if they are pre-approved as part of the “general approval” process (section 68CB of the TAA).

A general approval must be submitted by the 7<sup>th</sup> day of the second month after the end of the relevant income year. For example, a standard balance date payer must submit their general approval for the 2021–22 income year by 7 May 2022. This creates a timing issue for post-core supporting activities where a business does not anticipate in time that it will have claimable supporting activity in the following year under these rules.

Proposed new section 68CB(7B) of the TAA would give the Commissioner the power to vary a general approval to include supporting activity that occurs in the year after the relevant core R&D activity and would therefore be able to be included in a business' tax credit calculation under section LY 5. A variation must be applied for on or before the 7<sup>th</sup> day of the 14<sup>th</sup> month after the end of the relevant income year.

#### **Example 31**

Whizzy Ltd (standard balance date) started their R&D eligible project in the 2020–21 income year. A general approval was sought for their 2020–21 core and supporting activities. However, towards the end of the 2020–21 income year, Whizzy Ltd's health and safety team put an abrupt end to their R&D work. Whizzy Ltd has some unexpected supporting activity occurring in the 2021–22 year, but this was not included in the general approval.

Section 68CB(7B) would give Whizzy Ltd until 7 May 2023 to vary its 2020–21 general approval to include the supporting activities that occur in the one year after the end of its core R&D activity. If this process occurs after Whizzy Ltd files its supplementary return for the 2020–21 income year (due 31 April 2022), it would also need to request an amendment under section 113 of the TAA to revise its eligible expenditure amount upwards.

A transitional variation power is also proposed in new section 68CB(7C) for pre-core supporting activity arising in the 2019–20 income year. Businesses would have until 31 August 2022 to apply to include any supporting activities in their general approval for the 2020–21 income year. This short-term variation power is proposed as the due date for these general approvals would have passed before any legislation could be enacted permitting the activities to be claimed. This issue will not arise from the 2021–22 income year onwards as the business will be able to establish whether it had any eligible pre-core supporting activity in the one year prior when it submits its general approval for the particular year.

**Example 32**

Fizzy Ltd has supporting activity expenditure in the 2019–20 income year but the core activity only starts in the 2020–21 year. Fizzy Ltd should be able to claim the 2019–20 supporting activity expenditure in its 2020–21 supplementary return, but to do so the activity must have been approved in a general approval for the 2020–21 year.

Fizzy Ltd has until 31 August 2021 to submit its general approval under section 68CF of the TAA (the extended due date). Up until 31 August 2021, Fizzy Ltd could request that the Commissioner vary the approvals in the general approval. However, proposed new section 68CB(7C) would give Fizzy Ltd until 31 August 2022 to vary its 2020–21 general approval to include the supporting activities that occur one year before its core R&D activity (2019–20).

## **R&D TAX INCENTIVE – TRANSITIONAL SUPPORT PAYMENT**

---

*(Clauses 56, 64, and 132)*

### **Summary of proposed amendment**

Two proposed amendments to the proposed R&D Tax Incentive (RDTI) Transitional Support Payment (TSP) would:

- set the tax treatment of the TSP payment (taxable with corresponding expenditure deductible), and
- clarify that an existing exclusion from the RDTI for expenditure covered by a grant does not include the TSP.

### **Application date**

The proposed amendments would apply for the 2019–20 and later income years.

### **Key features**

Proposed new section CX 47(5) of the Income Tax Act 2007 (ITA) would ensure that section CX 47 does not treat the TSP (which may be a government grant) as excluded income. The result would be that the TSP is taxable and must be returned as income by the recipient business in the tax return for the income year the payment is received.

A corresponding amendment proposed for section DF 1(1BA) would carve out the TSP from the general rules that make expenditure corresponding to a government grant non-deductible. The result would be that expenditure covered by the TSP would be subject to the normal deductibility rules in part D.

Schedule 21B part B of the ITA excludes certain expenditure from being eligible for the RDTI. Clause 21 covers expenditure or loss that is a “precondition to, subject to the terms of, or required by, a grant” ineligible for the RDTI. The proposed amendment to this clause would ensure that receipt of the TSP does not make any expenditure or loss ineligible for the RDTI.

### **Background**

The Government has agreed to implement the TSP to provide additional support for former Callaghan Innovation Growth Grant businesses transitioning to the RDTI. The Growth Grant, which ended in March 2021, was the main R&D support product for these businesses before the introduction of the RDTI.

The TSP will take the form of an adjustment to a business’s RDTI entitlement so that it approximates what it would have received under the Growth Grant if that scheme had continued. It is available for the 2019–20 to 2021–22 income years. To claim the TSP, businesses must have been a former Growth Grant recipient and participate in the RDTI for

the relevant year. The details of the TSP were set by the Minister of Research, Science and Innovation in a Ministerial Direction notified in the *New Zealand Gazette*.<sup>17</sup>

The tax treatment of the TSP proposed by the amendment would be consistent with an option to treat the Growth Grant as taxable income provided for in the ITA (section CX 47(4)). This optional treatment recognised that the business may receive the grant in a different income year to when the corresponding expenditure arose. The same situation would occur in most cases for the TSP. Treating the payment as taxable, as with the Growth Grant, would eliminate significant compliance costs and the need for a business to later amend a previously filed tax return to reverse deductions that were no longer allowed.

Similarly, it is desirable to treat deductible expenditure in a matching way. That is, instead of expenditure being treated as non-deductible where the grant is non-taxable, the normal tax treatment would apply. This would eliminate difficult tracing and measurement or apportionment costs for the business and the need to seek an amended return.

---

<sup>17</sup> Woods, M. (6 July 2021). Direction to Callaghan Innovation—Administration of the R&D Tax Incentive Transition Support Payment. *New Zealand Gazette*. <https://gazette.govt.nz/notice/id/2021-go2770>



# ADMINISTRATIVE AMENDMENTS TO THE CHILD SUPPORT ACT 1991

---

*(Clauses 175–186)*

## Summary of proposed amendments

The recently enacted Child Support Amendment Act 2021 (CSAA) contained measures to improve the child support scheme. Following enactment, officials identified a group of minor and technical remedial changes to the Child Support Act 1991 (CSA) that are needed to give full effect to the policy intent of the recent amendments.

## Application date

The proposed amendment to the write-off rules would apply from 1 April 2021. This is for consistency with the repeal of certain types of penalties under the CSAA.

The other proposed amendments would apply from 1 April 2022.

## Key features

Table 3 summarises the proposed minor and technical remedial amendments to the CSA.

**Table 3: Child support issues and proposed amendments**

Topic	Issue	Proposed amendment
Estimations	The CSAA allows newly liable parents to backdate their estimations (provided the estimation is made within 28 days of the notification of the assessment). It was intended that the backdating would cover estimations both over back years and within the current child support year. However, the amendment only allows estimations over back years.	The proposed amendment would allow backdated estimations within the current child support year.
	Currently, a person could provide their initial estimate within 28 days and then submit a re-estimate within the same time period. Inland Revenue has no ability to refuse subsequent backdated estimations made by a newly liable parent.	The proposed amendment would allow subsequent backdated estimations to be declined because the period has ended and would be squared up.

<b>Topic</b>	<b>Issue</b>	<b>Proposed amendment</b>
End-of-year reconciliation	The new definition of “reconciliation period” under the CSAA does not result in the correct outcome for new backdated estimations. Currently, the definition refers to the first day of the month in which notice is given. Because the estimation is backdated, it will be given after the start date of the assessment. This means that if the reconciliation period begins on the first day of the month in which the notice of election is given, the reconciliation period will start too late to cover the correct period.	The proposed amendment would allow backdated estimations within the current child support year.
Change of family circumstances	The CSAA allows Inland Revenue to backdate an assessment to correct certain living circumstances that did not exist at the time of an initial assessment. Currently, Inland Revenue is not required to be satisfied that a relevant set of circumstances existed at the time of the assessment. Additionally, there is no requirement that the notification be accompanied by documentation.	The proposed amendment would ensure that Inland Revenue could be satisfied that the relevant circumstances existed at the time of the assessment, and also that the notification be accompanied by relevant documentation.
	Currently, the relevant provision refers to circumstances that existed at the time the assessment was made, as opposed to when it began. It is possible that family circumstances change between a child support application beginning and when the child support notification is made.	The proposed amendment would clarify that the relevant circumstances are those that existed when the assessment begins.
Time bar	The CSAA restricts reassessments of a child support year to four years from the end of a relevant child support year. Parents and carers are sent notification of their child support assessment in February each year and that assessment relates to the child support year starting on 1 April. As currently drafted, the time bar starts from the notification rather than the beginning of the relevant child support year.	The proposed amendment would allow the time bar to begin from the beginning of the child support year, rather than when notification of the assessment is given. This would ensure that it covers the intended four-year period.
	The CSAA provides an exception to the four-year time bar in circumstances where a liable person has a dual liability with an overseas jurisdiction. Currently, the exception refers to the payment of child support, as opposed to having been assessed to pay financial support. This means that the liable person must have “paid” financial support before the exception can be applied. However, at times dual liability may exist but neither liability has been paid, and this means Inland Revenue cannot apply the exception.	The proposed amendment would allow the exception to apply on assessment of a liability.

<b>Topic</b>	<b>Issue</b>	<b>Proposed amendment</b>
Temporary exemption	The CSAA introduces a new temporary exemption from paying child support for people who have a long-term illness or injury and who are subsequently unable to engage in paid work. Currently, an application only requires evidence that an individual has a long-term period of illness.	The proposed amendment would require an individual to provide evidence that they are unable to engage in paid work when submitting an application.
Offsetting	The CSAA allows Inland Revenue to offset child support amounts between parents without the person having to apply for an administrative review. However, it does not currently allow offsetting to occur under a voluntary agreement.	The proposed amendment would allow for the offsetting of a voluntary agreement.
Write-off rules	Inland Revenue can write off debt, including penalties, when a liable person or receiving carer dies. Currently, the relevant provision uses outdated terminology.	The proposed amendment would update the terms used.
Repeal of transitional provision	The CSAA includes a transitional provision to establish that the amendments introduced do not affect the 2020–21 child support years and earlier. This is not required.	The proposed amendment would repeal the transitional provision that is not required.
Child expenditure table	The CSAA removed the mixed aged bracket of the expenditure table for calculating a rate of child support. However, the heading still contains the words “or the oldest three”.	The proposed amendment would correct the heading.

## **Background**

In October 2021, the child support scheme will move to new systems and processes under Inland Revenue’s multi-year Business Transformation. This move will allow a greater degree of efficiency and simplicity, and it will also create opportunities for legislative changes to further improve the administration of the child support scheme.

The policy changes in the CSAA take advantage of this opportunity. Following enactment, officials identified a group of minor and technical remedial changes to the CSA that would be needed to give full effect to the policy intent of the recent amendments.

## **REMOVAL OF THE POWER TO REPEAL THE SFO INFORMATION SHARING CLAUSE**

---

*(Clause 201)*

### **Summary of proposed amendment**

The proposed amendment would remove the power to repeal clause 7 of schedule 7 of the Tax Administration Act 1994 (TAA) by an Order in Council.

### **Application date**

The proposed amendment would apply from the date of enactment.

### **Background**

The Taxation (KiwiSaver, Student Loans, and Remedial Matters) Act 2020 provides for clause 7 of schedule 7 of the TAA to be repealed on a date to be appointed by an Order in Council. This Order has not been made.

This empowering provision was enacted ahead of the implementation of the Serious Crime Approved Information Sharing Agreement (AISA), which was then progressing. The provision was intended to enable the AISA to be implemented correctly and to avoid two authorising provisions (the clause and the AISA) from being in place at the same time.

It has since transpired that, due to the information being shared, it is not necessary to repeal the clause. The proposed amendment would remove the power to repeal the clause by an Order in Council.

## **DEFINITIONS OF “SENSITIVE REVENUE INFORMATION” AND “REVENUE INFORMATION”**

---

*(Clause 139)*

### **Summary of proposed amendment**

The proposed amendments would clarify the definitions of “revenue information” and “sensitive revenue information” in section 16C(2) and section 16C(3) of the Tax Administration Act 1994 for the avoidance of doubt in their interpretation.

### **Application date**

The proposed amendments would apply from 18 March 2019.

### **Background**

If a court took a broad interpretation of “revenue information” and “sensitive revenue information”, all information held by the Commissioner (including non-tax related information) would need to be treated as sensitive revenue information. As a result, information that could be released by any other government agency, such as the number of lightbulbs purchased in a year, would have its release restricted for Inland Revenue. Therefore, a broad interpretation would negatively affect the interpretation and application of the confidentiality rules, which were modernised in 2019 with the aim of enabling more information held by Inland Revenue to be made available than previously.

These rules are not intended to impose restrictions on information held by Inland Revenue with no real connection to either the Commissioner or to Inland Revenue’s responsibility for tax law and the administration of the tax system.

Therefore, amendments are proposed to clarify the relevant terms and prevent broad interpretations. Practically this would have no implications for taxpayers or their information.

## REPEAL OF TRANSITIONAL CO-EXISTENCE PROVISIONS

---

*(Clauses 157–159(1))*

### **Summary of proposed amendment**

The proposed amendments repeal provisions in sections 139A(10), 139AA(7) and 139B(1B) of the Tax Administration Act 1994 (TAA) that relate to the co-existence of two software platforms. From 1 April 2022, only one software platform will be operating.

### **Application date**

The proposed amendments would apply for penalties imposed after 1 April 2022.

### **Background**

Inland Revenue has been updating its software platform as part of its Business Transformation (BT) programme. During the duration of that programme, several transitional provisions were introduced to support co-existence of the old platform, FIRST, and the new START platform.

In October 2021, the final stage of BT will see all tax products migrated to the new START platform, with FIRST being decommissioned, and the transitional provisions relating to the co-existence of two software platforms will no longer be required. The proposed amendments would remove those provisions from sections 139A, 139AA and 139B of the TAA.

## **AMENDING AND LATER REPEALING THE DEFINITION OF “START TAX TYPE”**

---

*(Clauses 135(6 – 7), and 170)*

### **Summary of proposed amendment**

The proposed amendments would add three new tax types to the definition of “START tax type” in section 3 of the Tax Administration Act 1994 (TAA) from 1 March 2021 and then repeal the definition of “START tax type” from 1 April 2022 because all tax types will have been migrated into the START system by that date and the definition will be redundant.

### **Application date**

The proposed amendment to add three new tax types to the definition of “START tax type” would apply from 1 March 2021.

The proposed amendment to delete the “START tax type” definition would apply from 1 April 2022.

### **Background**

Inland Revenue has been progressively adding tax types from its old technology platform, FIRST, to its new START system as part of its Business Transformation programme.

From 1 March 2021, three new tax types (casino duty, lottery duty, and totalisator duty) were added to the START system. The proposed amendment would add those tax types to the definition of “START tax type”. This definition is used in section 183C of the TAA, which relates to the cancellation of interest.

In October 2021, Inland Revenue will complete its shifting of all tax types to START. At that point, the definition of “START tax type” will be redundant, and it is proposed the definition be repealed from 1 April 2022.

Consequential amendments are also proposed to section 183C of the TAA to replace references to “START tax type” once the definition is repealed.

## **PREVENTING CIRCULARITY OF KIWISAVER EMPLOYER CONTRIBUTIONS**

---

*(Clause 188(3))*

### **Summary of proposed amendment**

The proposed amendment to the definition of “employer contribution” in section 4 of the KiwiSaver Act 2006 (KSA) would provide that an employer need not pay an employer KiwiSaver contribution if the employer knows that the employee has opted out.

### **Application date**

The proposed amendment would apply from the date of enactment.

### **Background**

Under section 93 of the KSA, an employer is required to pay all amounts of employer KiwiSaver contributions to the Commissioner. Where an employee opts out of KiwiSaver, Inland Revenue is required to refund that money to the employer under section 100 of the KSA. However, the interaction of section 93 and section 100 can produce a circularity of cash flow by requiring the employer to pay a KiwiSaver contribution to Inland Revenue that Inland Revenue must in turn refund to the employer.

This specifically arises where the employer owes KiwiSaver employer contributions in connection with a period that precedes the employee having opted out of KiwiSaver, and the employer has not yet received a notice to cease payment of KiwiSaver employer contributions from Inland Revenue after the employee has opted out of KiwiSaver under section 19 of the KSA.

The proposed amendment would exclude an amount from being an employer contribution if the employer knows that the employee has opted out.



## **ACC AND KIWISAVER BEING MADE SUBJECT TO A TIME BAR**

---

*(Clauses 146, 147, 149–151, 154, 156, 189–191, and 193–197)*

### **Summary of proposed amendment**

This proposed amendment would introduce a four-year time bar on increased and decreased assessments of KiwiSaver employer and employee deductions and increased assessments of ACC earners' levy deductions. This treats KiwiSaver employer and employee deductions and ACC earners' levy deductions the same as other PAYE deductions for time bar purposes.

### **Application date**

The proposed amendments would apply from the date of enactment.

### **Key features**

Proposed new section 108AB would be inserted into the Tax Administration Act 1994 (TAA). The provision would apply to both employer and employee deductions and provide a four-year time bar on amended assessments of KiwiSaver deductions (both employer and employee) that increase an amount assessed.

However, where the employer information provided by the employer is fraudulent or wilfully misleading, the Commissioner would be able to amend an assessment at any time to increase the amount assessed.

A proposed new paragraph inserted into section 108(1C) of the TAA would provide that the Commissioner may not amend an assessment of ACC earners' levy deductions to increase the amount of an assessment after a period of four years from the date the employer provided the return.

Proposed new section 91B would be inserted into the KiwiSaver Act 2006 (KSA). This section would provide that the Commissioner and KiwiSaver providers must not refund employee and employer contributions after the four-year period under section 108AB has ended.

There are also several consequential amendments proposed to the TAA and the KSA to give effect to these changes.

More time is required to work through how a time bar on refunds for overpayments of ACC earners' levy deductions would apply and any changes will be included in a future Bill.

### **Background**

The TAA imposes a four-year time bar on the amendment of tax assessments. The time bar means that, once four years have passed, the Commissioner of Inland Revenue may not amend an assessment so as to increase the amount assessed or decrease the amount of a net loss. There are a limited number of exceptions to this period, most notably that it does not apply in instances of fraud. Similarly, the Income Tax Act 2007 imposes a four-year time

bar on taxpayers' ability to claim a refund for overpayments of tax. Both time bars are present to provide certainty within the tax system and to taxpayers.

The KSA legislates that employer and employee deductions are subject to the PAYE rules.<sup>18</sup> However, this requirement does not capture increased assessments or refunds of KiwiSaver employer and employee deductions for the purposes of the time bar.

The consequence of this is that, for time bar purposes, KiwiSaver employee and employer deductions and ACC earners' levy deductions are not treated consistently with other PAYE deductions that are subject to the time bar. This increases uncertainty and exposure to ongoing liabilities for taxpayers, KiwiSaver providers and Inland Revenue.

---

<sup>18</sup> In section 67 of the KiwiSaver Act 2006.

## **PENALTY FOR FAILURE TO KEEP TAXPAYER INFORMATION CONFIDENTIAL**

---

*(Clause 166)*

### **Summary of proposed amendment**

The proposed amendment would reinstate the penalty for failure by employees of another agency to keep taxpayer information confidential. These employees were unintentionally omitted when changes were made to the penalty provision in the Tax Administration Act 1994 (TAA) in 2019.

### **Application date**

The proposed amendment would apply from 18 March 2019, the date that the employees of other agencies were omitted from the penalty provision.

### **Key features**

Section 143D of the TAA describes the instances where a person, having access to taxpayer information, commits an offence for failing to keep taxpayer information confidential. The proposed amendment would insert a new subparagraph into section 143D(1) to refer to situations where the Commissioner shares taxpayer information with other agencies and their employees.

### **Background**

Inland Revenue currently shares taxpayer information with 22 other agencies to assist those agencies in providing public services. Employees of these other agencies are required to keep this information confidential under the TAA. Before March 2019, failure by an employee of another agency to keep taxpayer information confidential was included in the offence provision under the TAA and punishable by a maximum penalty of \$15,000 and/or a term of imprisonment of up to six months. Inland Revenue employees are also subject to the same confidential obligation and penalty.

With the enactment of the Taxation (Annual Rates for 2018–19, Modernising Tax Administration, and Remedial Matters) Act 2019 in March 2019, changes were made to the offence provisions in the TAA. However, an unintended outcome of these changes was that the references to situations where employees of other agencies receive taxpayer information was omitted.



---

# Maintenance items

---



## MAINTENANCE AMENDMENTS

---

### Summary of proposed amendments

The proposed amendments in table 4 are minor technical maintenance items arising from both the rewrite of income tax legislation and subsequent changes.

### Application dates

Application dates for each proposed amendment are stated in table 4.

### Minor maintenance items

The proposed amendments in table 4 would correct any of the following:

- ambiguities
- compilation issues
- cross-references
- drafting consistency, including readers' aids – for example, the defined terms lists
- grammar
- consequential amendments arising from substantive rewrite amendments, and
- inconsistent use of terminology and definitions.

**Table 4: Maintenance amendments**

Act	Clause	Section	Amendment	Application date
Goods and Services Tax Act 1985	7(1)	5(6AB)	Correcting terminology	1 July 2017
	7(2)	5(6E)(b)(ii)	Correcting cross-references	1 April 2010
Income Tax Act 2007	47	BC 5	Correcting the defined terms list	1 April 2008
	61	DB 20B	Correcting the defined terms list	1 April 2013
	66	EE 6	Correcting the defined terms list	1 April 2019
	68	EE 44(2)(d)	Correcting terminology	4 September 2010
	69	EJ 10B(6)	Correcting terminology	1 January 2019
	84	FO 2(b)	Correcting cross-references	1 April 2008

<b>Act</b>	<b>Clause</b>	<b>Section</b>	<b>Amendment</b>	<b>Application date</b>
	87	HF 7	Improving drafting consistency	1 April 2008
	88	HR 3(6A)(f)	Correcting terminology	30 January 2021
	93	LY 9	Correcting terminology	1 April 2019
	94	LY 10	Correcting terminology	1 April 2019
	95(1)	MD 9(1)(a)	Correcting terminology	1 April 2021
	95(2)–(4)	MD 9(4), (5), (9)	Improving drafting consistency	1 July 2020
	96	MX 3(3)	Correcting cross-references	30 March 2017
	97	OA 9(3)	Correcting cross-references	1 April 2008
	113	RD 5(1)(c)	Correcting cross-references	30 March 2017
	120	RM 1	Correcting defined terms list	1 April 2017
	127(3)	YA 1 “date of acquisition”	Correcting cross-references	27 March 2021
	127(5)	YA 1 “dwelling”	Correcting cross-references	27 March 2021
	127(8)	YA 1 “group of persons”	Correcting cross-references	27 March 2021
	127(9)	YA 1 “group of persons”	Correcting cross-references	30 March 2021
	127(13)	YA 1 “principal settlor”	Correcting terminology	27 March 2021
	127(16), (18)	YA 1 “residential land”	Correcting terminology	27 March 2021
	127(17)	YA 1 “settlement”	Correcting cross-references	27 March 2021
	130	YE 1(6)	Correcting terminology	1 April 2008



<b>Act</b>	<b>Clause</b>	<b>Section</b>	<b>Amendment</b>	<b>Application date</b>
Tax Administration Act 1994	135(5)	3 “proscribed question”	Improving drafting consistency	1 October 2019
	135(8)	3 “tax shortfall”	Correcting cross-references	1 April 2019
	152	113(1)	Correcting cross-references	1 April 2019
		157A(1)	Correcting cross-references	Assent
	171–172, 202–204	225, 225AA	Revoking redundant regulations	Assent
	174	Schedule 8	Correcting cross-references and terminology	1 April 2020
KiwiSaver Act 2006	192	83(3)(c)	Correcting terminology	30 March 2021